

XIFLUX:10



10 HP Cyclone Owner's Manual

10HP EXPLOSION-SUPPRESSION SYSTEM

LAGUNA



TABLE OF CONTENTS

Important Safety Instructions.....	2
Safety Guidelines - Definitions.....	5
General Safety Rules.....	6
Additional Safety, Dust Collectors.....	6
Power Connections.....	9
Motor Specifications.....	10
Grounding Instructions.....	10
Key Features and Components.....	11
Functional Description.....	11
Product Specifications.....	12
Unpacking.....	13
Assembly.....	14
General Tool Assembly.....	14
Maintenance Procedures.....	22
Cleaning the Filter.....	22
Changing the Filter Bag.....	24
Emptying the Drum.....	24
Routine Inspection.....	25
Trouble Shooting.....	26
Parts breakdown and parts list.....	28
Warranty.....	35

LATEST MANUAL:

Below is a QR code which will direct you to the manual reference page, where the latest version of the 10 HP DUST COLLECTOR manual is located on the Laguna Tools website. The online manual may have updates and information added after the printed copy was released. Scan the code with your smartphone or copy the URL link to be directed to the latest manual page to reference your specific machine and model.

<https://lagunatools.com/resources/product-manuals/#industrial>



IMPORTANT SAFETY INSTRUCTIONS



WARNING READ AND UNDERSTAND ALL WARNINGS AND OPERATING INSTRUCTIONS BEFORE USING THIS EQUIPMENT. Failure to follow all instructions listed below, may result in electric shock, fire, and/or serious personal injury or property damage.

Woodworking can be dangerous if safe and proper operating procedures are not followed. As with all machinery, there are certain hazards involved with the operation of the product. Using the machine with respect and caution will considerably lessen the possibility of personal injury. However, if normal safety precautions are overlooked or ignored, personal injury to the operator may result. Safety equipment such as guards, push sticks, hold-downs, featherboards, goggles, dust masks and hearing protection can reduce your potential for injury. But even the best guard won't make up for poor judgment, carelessness or inattention. **Always use common sense** and exercise caution in the workshop. If a procedure feels dangerous, don't try it. Figure out an alternative procedure that feels safer. **REMEMBER:** Your personal safety is your responsibility.



WARNING This machine was designed for certain applications only. We strongly recommend that this machine not be modified and/or used for any application other than that for which it was designed. If you have any questions relative to a particular application, DO NOT use the machine until you have first contacted the manufacturer to determine if it can or should be performed on the product.

If you have any questions to its applications, DO NOT use the product until you have contacted the manufacturer and we have advised you.

When using an electrical appliance, basic precautions should always be followed, including the following:

READ ALL INSTRUCTIONS BEFORE USING (THIS APPLIANCE)



WARNING To reduce the risk of fire, electric shock, or injury:

1. Do not leave appliance unattended when plugged in. Unplug from outlet when not in use and before servicing.
2. Do not use outdoors or on wet surfaces.
3. Do not allow to be used as a toy. Close attention is necessary when used by or near children.
4. Use only as described in this manual. Use only manufacturer's recommended attachments.



5. Do not use with damaged cord or plug. If appliance is not working as it should, has been dropped, damaged, left outdoors, or dropped into water, return it to a service center.
6. Do not pull or carry by cord, use cord as a handle, close a door on cord, or pull cord around sharp edges or corners. Do not roll appliance over cord. Keep cord away from heated surfaces.
7. Do not unplug by pulling on cord. To unplug, grasp the plug, not the cord.
8. Do not handle plug or appliance with wet hands.
9. Do not put any object into openings. Do not use with any opening blocked; keep free of dust, lint, hair, and anything that may reduce air flow.
10. Keep hair, loose clothing, fingers, and all parts of body away from openings and moving parts.
11. Turn off all controls before unplugging.
12. Use extra care when cleaning on stairs.
13. Do not use to pick up flammable or combustible liquids, such as gasoline, or use in areas where they may be present.
14. Connect to a properly grounded outlet only. See Grounding Instructions.

SAVE THESE INSTRUCTIONS

1. Read and understand the warnings posted on the machine and in this manual. Failure to comply with all of these warnings may cause serious injury.
2. Replace the warning labels if they become obscured or removed.
3. This 3HP Portable Cyclone Dust Collector is designed and intended for use by properly trained and experienced personnel only. If you are not familiar with the proper and safe operation of this type of dust collector, do not use until proper training and knowledge have been obtained.
4. Do not use this machine for other than its intended use. If used for other purposes, **LAGUNA TOOLS INC.**, disclaims any real or implied warranty and holds itself harmless from any injury that may result from that use.
5. Always wear approved safety glasses/face shields while using this machine.
6. Before operating this dust collector, remove tie, rings, watches and other jewelry, and roll sleeves up past the elbows. Remove all loose clothing and confine long hair. Non-slip footwear or anti-skid floor strips are recommended. Do **not** wear gloves.
7. Wear ear protectors (plugs or muffs) during extended periods of operation.
8. Some dust created by power sanding, sawing, grinding, drilling, and other construction activities contain chemicals known to cause cancer, birth defects or other reproductive harm. Some examples of these chemicals are:
 - Lead from lead-based paint.

LAGUNA

- Crystalline silica from bricks, cement, and other masonry products.
- Arsenic and chromium from chemically treated lumber.

Your risk of exposure varies, depending on how often you do this type of work. To reduce your exposure to these chemicals, work in a well-ventilated area and work with approved safety equipment, such as face or dust masks that are specifically designed to filter out microscopic particles.

9. Do not operate this machine while tired or under the influence of drugs, alcohol or any medication.
10. Make certain the switch is in the **OFF** position before connecting the machine to the power source.
11. Make certain the machine is properly grounded.
12. Make all machine adjustments or maintenance with the machine unplugged from the power source.
13. Form a habit of checking to see that all extra equipment such as adjusting keys, wrenches, scrap, stock, and cleaning rags are removed away from the machine before turning on.
14. Keep safety guards in place at all times when the machine is in use. If removed for maintenance purposes, use extreme caution, and replace the guards immediately when maintenance is complete.
15. Make sure the dust collector is on a flat, even surface and the wheels locked in place before use.
16. Check damaged parts. Before further use of the machine, a guard or other part that is damaged should be carefully checked to determine that it will operate properly and perform its intended function. Check for alignment of moving parts, binding of moving parts, breakage of parts, mounting and any other conditions that may affect its operation. A guard or other part that is damaged should be properly repaired or replaced.
17. Provide adequate space surrounding work area and non-glare, overhead lighting.
18. Keep the floor around the machine clean and free of scrap material, oil and grease.
19. Keep visitors a safe distance from the work area. **Keep children away.**
20. Make your workshop child proof with padlocks, master switches or by removing starter keys.



21. Give your work undivided attention. Looking around, carrying on a conversation and “horseplay” are careless acts that can result in serious injury.
22. Maintain a balanced stance at all times so that you do not fall or lean against the dust collector. Do not overreach or use excessive force to perform any machine operation.
23. Use the right tool at the correct speed and feed rate. Do not force a tool or attachment to do a job for which it was not designed. The right tool will do the job better and safer.
24. Use recommended accessories; improper accessories may be hazardous.
25. Maintain machinery with care. Follow instructions for lubricating and changing accessories.
26. Turn off the machine before cleaning. Use a brush or compressed air to remove dust or debris — do not use your hands.
27. Do not stand on the machine. Serious injury could occur if the machine tips over.
28. Never leave the machine running unattended. Turn the power off and do not leave the machine until it comes to a complete stop.

Familiarize yourself with the following safety notices used in this manual:

SAFETY GUIDELINES - DEFINITIONS

This manual contains information that is important for you to know and understand. This information relates to protecting YOUR SAFETY and PREVENTING EQUIPMENT PROBLEMS. To help you recognize this information, we use the symbols below. Please read the manual and pay attention to these sections.



Indicates an imminently hazardous situation which, if not avoided, will result in death or serious injury.



Indicates a potentially hazardous situation which, if not avoided, could result in death or serious injury.

LAGUNA

⚠ CAUTION

Indicates a potentially hazardous situation which, if not avoided, may result in minor or moderate injury.

⚠ CAUTION

Used without the safety alert symbol indicates potentially hazardous situation which, if not avoided, may result in property damage.

GENERAL SAFETY RULES

⚠ WARNING

WARNING FAILURE TO FOLLOW THESE RULES MAY RESULT IN SERIOUS PERSONAL INJURY.

FOR YOUR OWN SAFETY, READ AND UNDERSTAND THE INSTRUCTION MANUAL BEFORE OPERATING THE MACHINE. Learn the unit's application and limitations as well as the specific hazards peculiar to it.

KEEP WORK AREA CLEAN. Cluttered areas and benches invite accidents.

DON'T USE IN DANGEROUS ENVIRONMENT. Don't use this unit in damp or wet locations or expose it to rain. Keep the work area well-lighted.

KEEP CHILDREN AND VISITORS AWAY. All children and visitors should be kept at a safe distance from work area.

DISCONNECT UNIT before servicing.

CHECK DAMAGED PARTS. Before further use of the unit, properly repair or replace any part that is damaged.

⚠ WARNING

FAILURE TO FOLLOW THESE RULES MAY RESULT IN SERIOUS INJURY.

ADDITIONAL SAFETY FOR DUST COLLECTORS

Intended use. This dust collector is only intended for collecting wood dust and chips from woodworking machines. Do not use this dust collector to collect metal, dirt, pebbles, drywall, asbestos, lead paint, silica, liquids, aerosols, or any flammable, combustible, or hazardous materials.



Hazardous dust. Dust created while using machinery may cause cancer, birth defects, or long-term respiratory damage. Be aware of dust hazards associated with each work piece material, and always wear a NIOSH-approved respirator to reduce your risk.

Dust allergies. Dust from certain woods may cause an allergic reaction in people and animals.

Make sure you know what type of wood dust you will be exposed to in case there is a possibility of an allergic reaction.

Wear a respirator. Fine dust that is too small to be caught in the filter will be blown into the ambient air during operation. Always wear a NIOSH-approved respirator during operation and for a short time after to reduce your risk of permanent respiratory damage.

Emptying dust. When emptying dust from the collection container, wear a respirator and safety glasses. Empty dust away from ignition sources and into an approved container.

Disconnecting power supply. Turn the switch off, disconnect the dust collector from the power supply, and allow the impeller to come to a complete stop before leaving the machine unattended or doing any service, cleaning, maintenance, or adjustments.

Suspended dust particles and ignition sources. Do not operate the dust collector in areas where explosion risks are high. Areas of high risk include, but are not limited to, areas near pilot lights, open flames, or other ignition sources.

Fire suppression. Only operate the dust collector in locations that contain a fire suppression system or have a fire extinguisher nearby.

Impeller hazards. Do not place your hands or tools near the open inlet during operation for any reason. The powerful suction could easily cause accidental contact with the impeller, which will cause serious personal injury or damage to the machine. Always keep small animals and children away from open dust collection inlets.

Avoiding sparks. Do not allow steel or rocks to strike the impeller—this may produce sparks. Sparks can smolder in wood dust for a long time before a fire is detected. If you accidentally cut into wood containing tramp metal (nails, staples, spikes, etc.), immediately turn **off** the dust collector, disconnect it from power, and wait for the impeller to stop—then empty the collection container into an approved airtight metal container.

Operating location. To reduce respiratory exposure to fine dust, locate permanently installed dust collectors away from the working area, or in another room that is equipped with a smoke detector. Do not operate the dust collector in rainy or wet locations—exposure to water may create a shock hazard or decrease the life of the machine.

LAGUNA

Static electricity. Plastic dust lines generate high amounts of static electricity as dust chips pass through them. Although rare, sparks caused by static electricity can cause explosions or fire. To reduce this risk, make sure all dust lines are thoroughly grounded by using a grounding wire.

Regular cleaning. Regularly check/empty the collection bags or drum to avoid the buildup of fine dust that can increase the risk of fire. Make sure to regularly clean the surrounding area where the machine is operated—excessive dust buildup on overhead lights, heaters, electrical panels, or other heat sources will increase the risk of fire.

CAUTION

This means that if precautions are not heeded, it may result in minor injury and/or possible machine damage.

WARNING

This means that if precautions are not heeded, it may result in serious injury or possibly even death.

**SAVE THESE INSTRUCTIONS.
Refer to them often and use them to instruct others.**

POWER CONNECTIONS/ELECTRICAL DIAGRAM

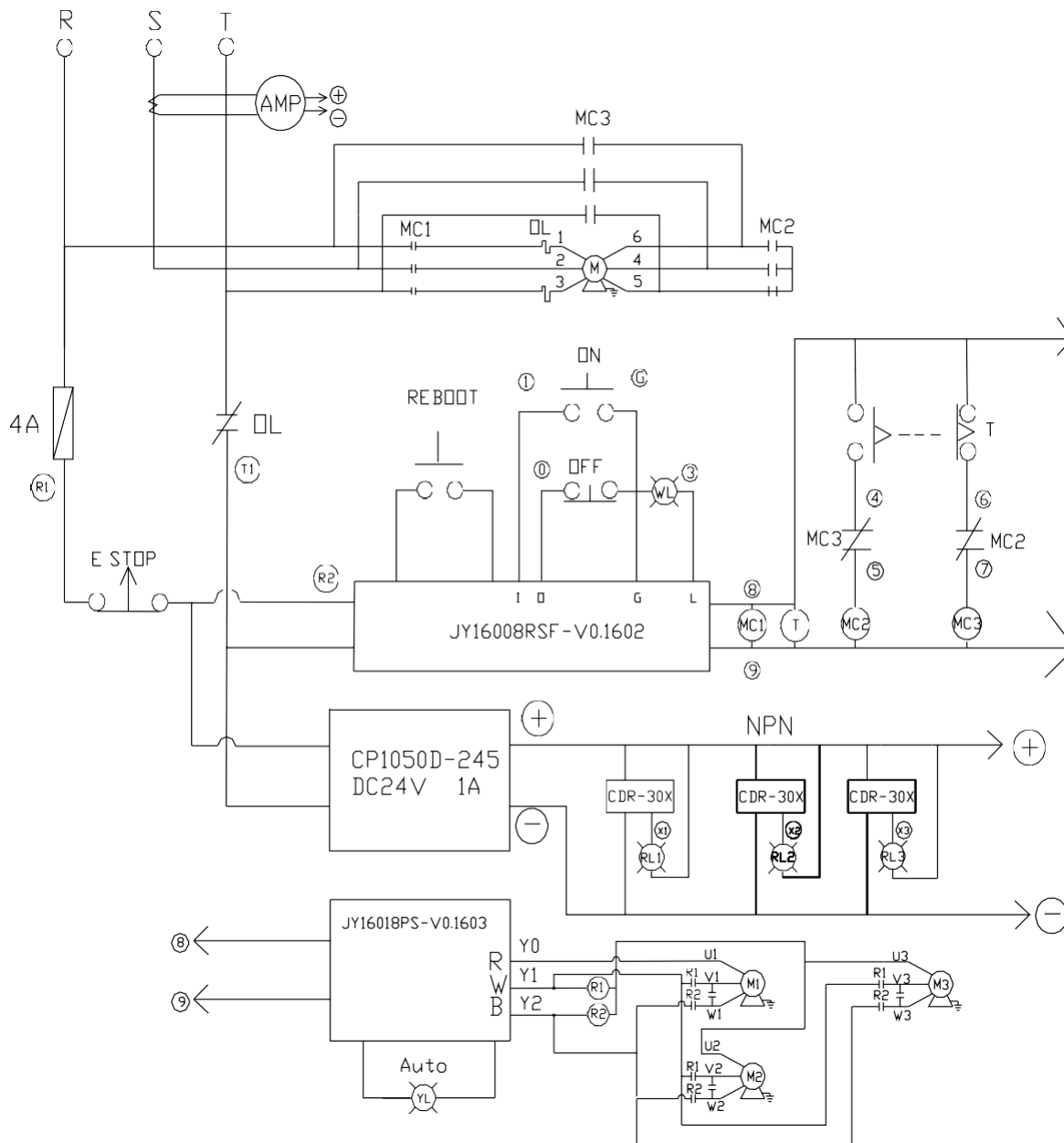

DO NOT EXPOSE THE MACHINE TO RAIN OR OPERATE THE MACHINE IN DAMP LOCATIONS.



MOTOR SPECIFICATIONS

Your machine is wired for 220 volts, 60 HZ alternating current. Before connecting the machine to the power source, make sure the switch is in the "OFF" position.

GROUNDING INSTRUCTIONS



THIS MACHINE MUST BE GROUNDED WHILE IN USE TO PROTECT THE OPERATOR FROM ELECTRIC SHOCK.

1. This appliance must be connected to a grounded metal, permanent wiring system; or an equipment-grounding conductor must be run with the circuit conductors and connected to the equipment-grounding terminal or lead on the appliance.

The installer, such as a qualified electrician, cut (or bend over) and insulate the grounding conductor from a field wiring supply cable.

In the event of certain types of malfunctions or breakdowns, grounding provides a path of least resistance for electric current—in order to reduce the risk of electric shock.

Improper connection of the equipment-grounding wire can result in a risk of electric shock. The wire with green insulation (with or without yellow stripes) is the equipment-grounding wire. If repair or replacement of the power cord or plug is necessary, do not connect the equipment-grounding wire to a live (current carrying) terminal.

Check with a qualified electrician or service personnel if you do not understand these grounding requirements, or if you are in doubt about whether the tool is properly grounded. If you ever notice that a cord or plug is damaged or worn, disconnect it from power, and immediately replace it with a new one.

Full Load amperage Draw

Amp draw at 220V (prewired)..... 28 Amps

Power Supply Circuit Requirements

The power source circuit for your machine must be grounded and rated for the amperage given below. Never replace a circuit breaker on an existing circuit with one of higher amperage without consulting a qualified electrician to ensure compliance with wiring codes. **If you are unsure about the wiring codes in your area or you plan to connect your machine to a shared circuit, consult a qualified electrician.**

Circuit Size (220V)..... 50 Amps



IN ALL CASES, MAKE CERTAIN THE RECEPTACLE IN QUESTION IS PROPERLY GROUNDED. IF YOU ARE NOT SURE, HAVE A QUALIFIED ELECTRICIAN CHECK THE RECEPTACLE.

LAGUNA

220 VOLT Three-Phase Operation

The motor supplied with your machine is a 220 volt motor. It is shipped ready-to-run for 220 volt, 3 Ph operation.

FUNCTION

High frequency remote control switch

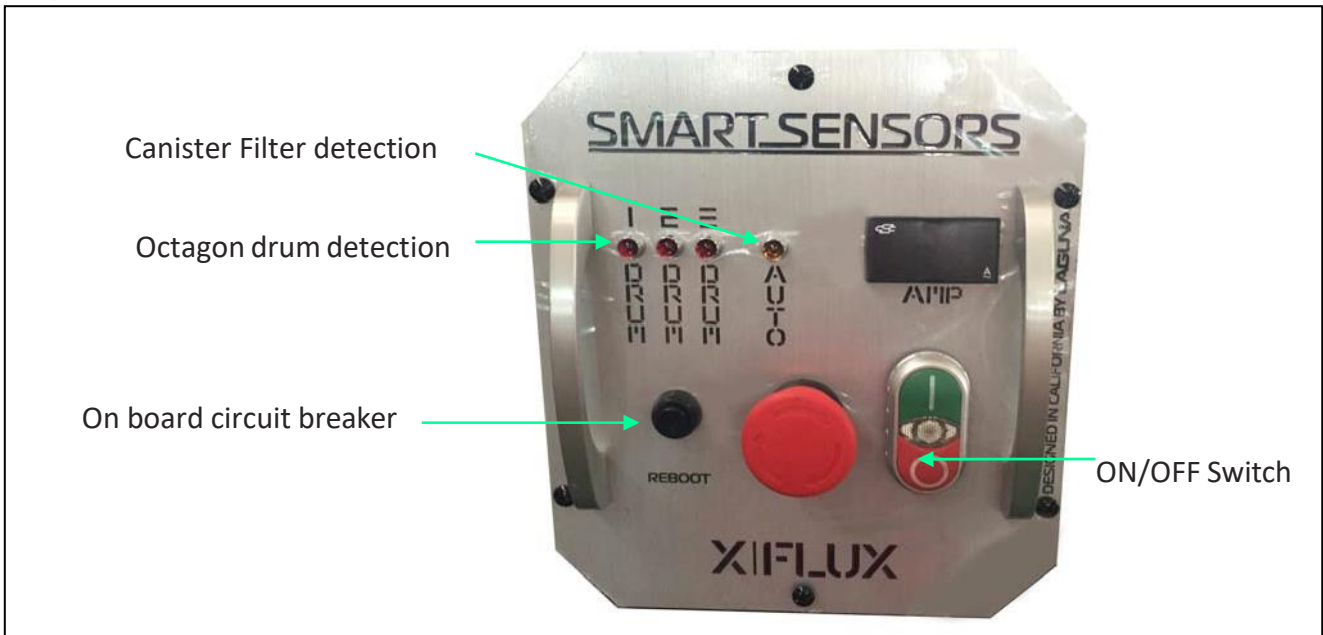

Handheld remote controller

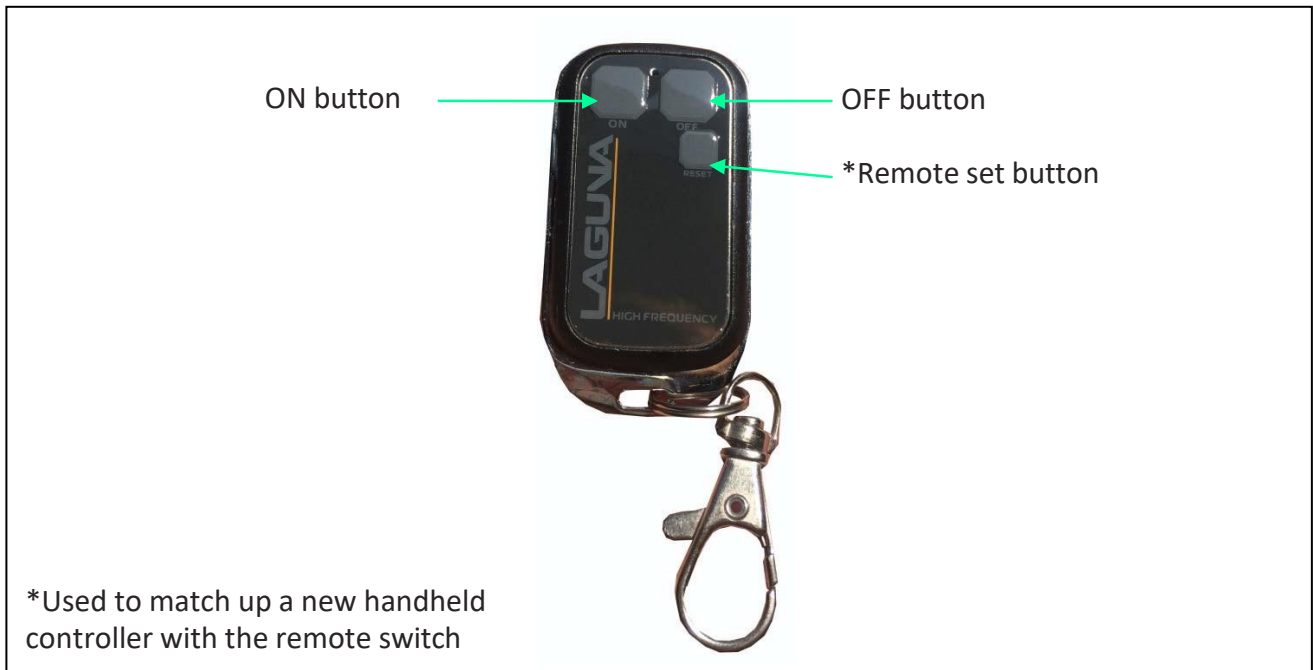



PRODUCT SPECIFICATIONS

Motor Specs:	10 HP
Electrical Specs:	220V / 60Hz / 3PH / 3450 RPM
Running AMP	(12" inlet) 28A at 220V
Air Volume:	4700CFM (cubic feet per minute)
Max. static pressure	11 Inches of water
Fan size	15.5"
Inlet:	Ø12"
Switch	High frequency remote control switch
Collection capacity	54 gallon, Octagon drum x 3sets
Packing Size: (L x W x H)	107.1" x 49.6" x 80.7" (272 x 126 x 205 cm)
Machine weight	1653.5 lbs. (750 kgs)
Shipping weight	1829.8 lbs. (830 kgs)

<u>Filter Media</u>	filtering area: 24.3m ² (261.6 ft ²)
Cartridge Filter	1 Micron Ø20.08" x 35.43" (Ø51 x 90cm) x 3 pcs.

LAGUNA

UNPACKING

Your 10HP Explosion Suppression Vacuum Dust Collector comes packed in a single wooden crate. Before attempting to assemble this machine, follow these directions for unpacking:

1. Carefully remove the wooden crate walls.
2. Carefully take out the machine components from the box and set aside.
3. Using the diagram below, ensure that all parts are present and in good condition.



DESCRIPTION (QUANTITY) Figure 1

- | | |
|-------------------------------|--------------------------------------|
| A. Motor | I. Left upright support panel |
| B. Front door | J. Right upper support panel |
| C. Silencer | K. Drum side panel (6) |
| D. Control panel | L. Drum front (3) and back panel (3) |
| E. Handheld remote controller | M. Drum base panel (3) |
| F. Drum vacuum hose (3) | N. Hardware box |
| G. Handheld remote controller | O. Operating and Parts Manual |
| H. Vacuum suction plate (3) | P. Intake 12" |

Report any missing or damaged parts to your dealer or distributor. Prior to tool assembly and use, read this manual thoroughly to familiarize yourself with proper assembly, maintenance, and safety procedures.

GENERAL TOOL ASSEMBLY



WARNING This step requires two adults. This 10HP Explosion Suppression Vacuum Dust Collector is heavy, be careful when lifting and handling it! Failure to comply may cause serious injury and/or damage to the machine and/or property!

Tools Required

10mm wrench / 12mm wrench / 14mm wrench

Phillips screwdriver

4mm hex wrench / 5mm hex wrench

To assemble your dust cyclone, follow these steps:

For your own safety, do not connect the machine to the power source until the machine is completely assembled. Please also make sure that you read and understand the entire instruction manual.

ASSEMBLY TIME ESTIMATE 1 - 2 hours

Step One: Use a forklift to lift the unit up by inserting the forks into the bottom as shown below. Be careful not to hit the proximity sensors on the drum lid when inserting the forks.

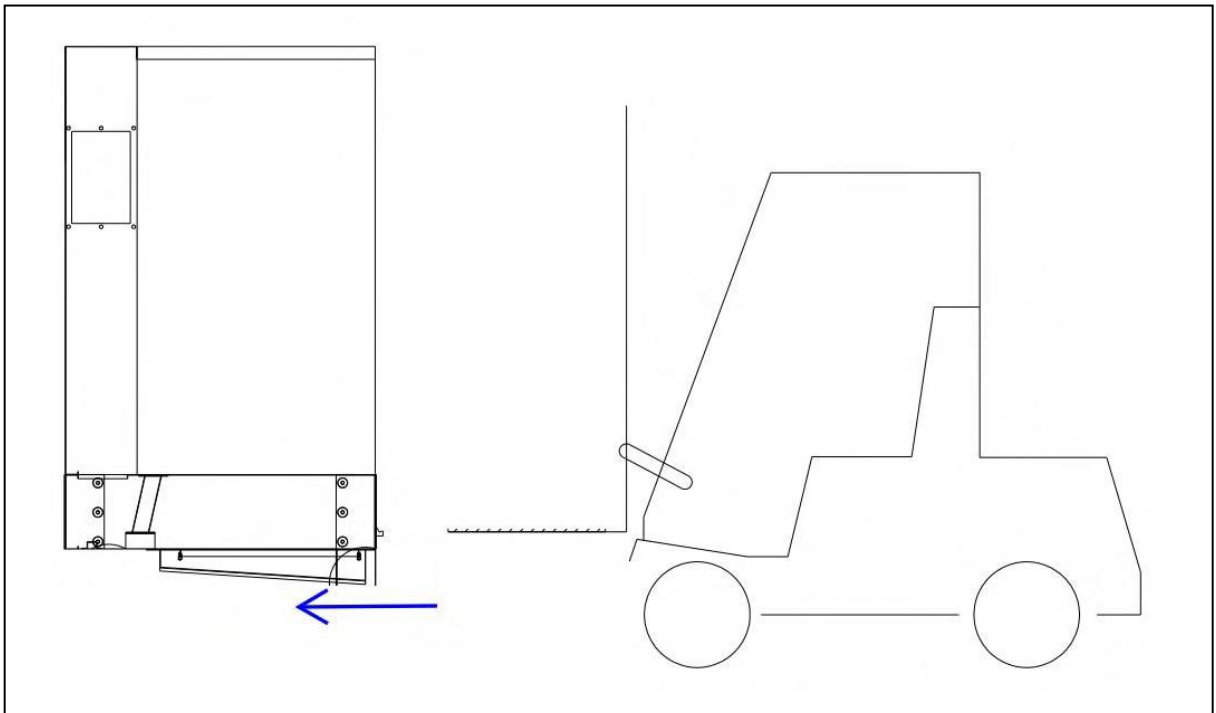

LAGUNA

Step Two: Secure the four wheels to the upright support panels using (16) 3/8"x1" hex bolts and (16) 3/8"x23x2 flat washers.

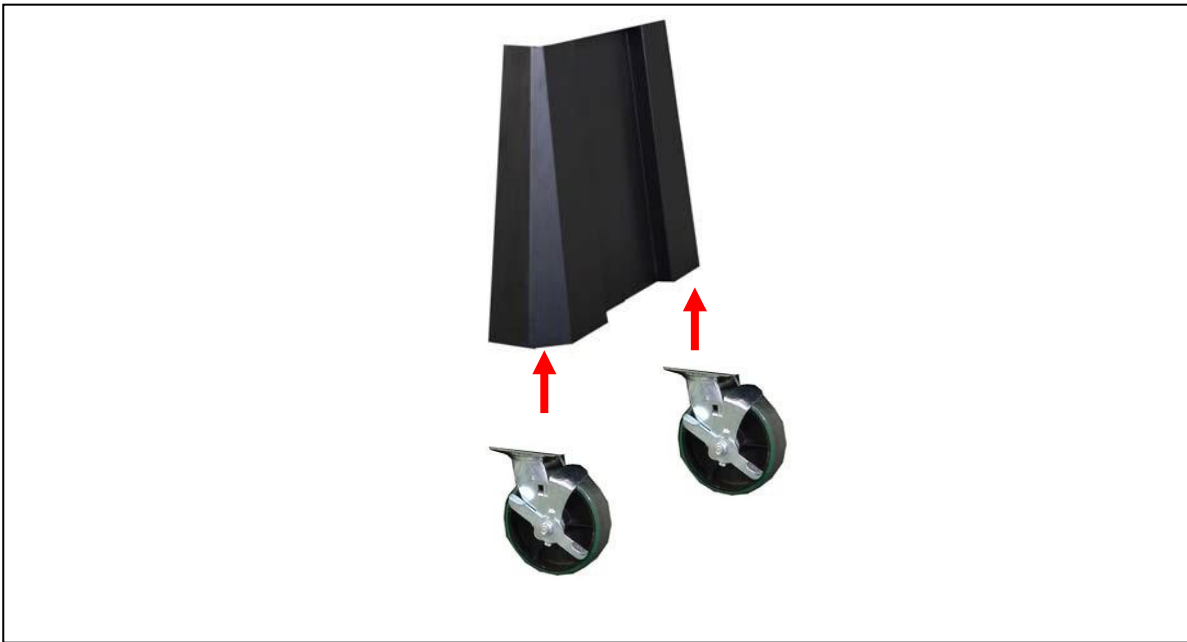

Step Three. Secure the upright support to the right side of the machine when facing the control panel. Use (13) 3/8"x1" hex bolts and (13) 3/8"x23x2 flat washers.

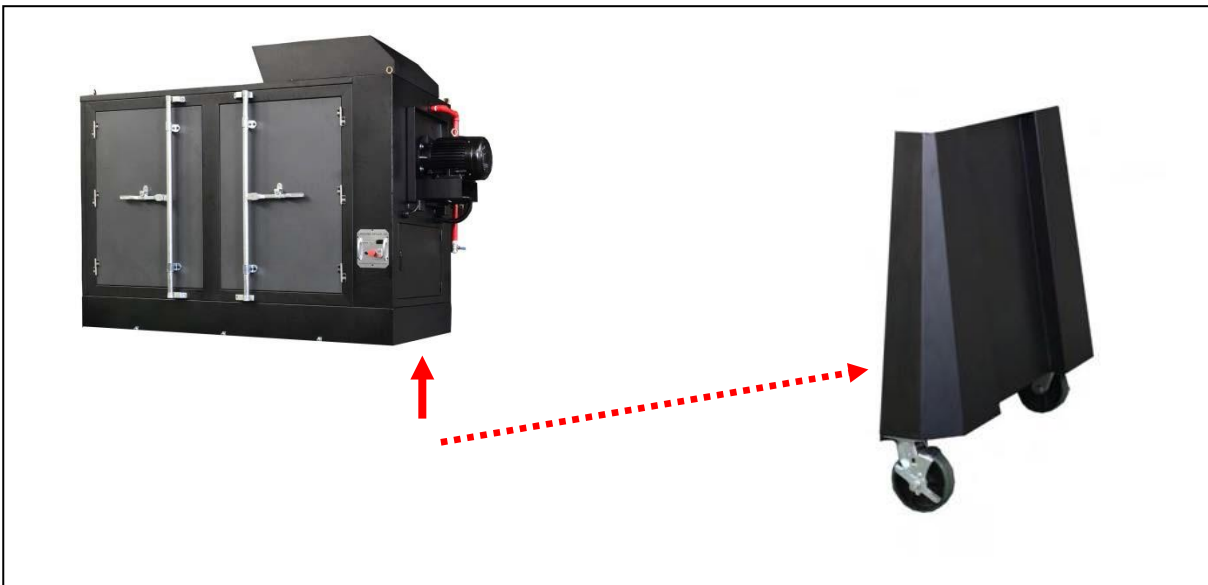

LAGUNA

Step Three. Secure the upright support to the left side of the machine when facing the control panel. Use (13) 3/8"x1" hex bolts and (13) 3/8"x23x2 flat washers.

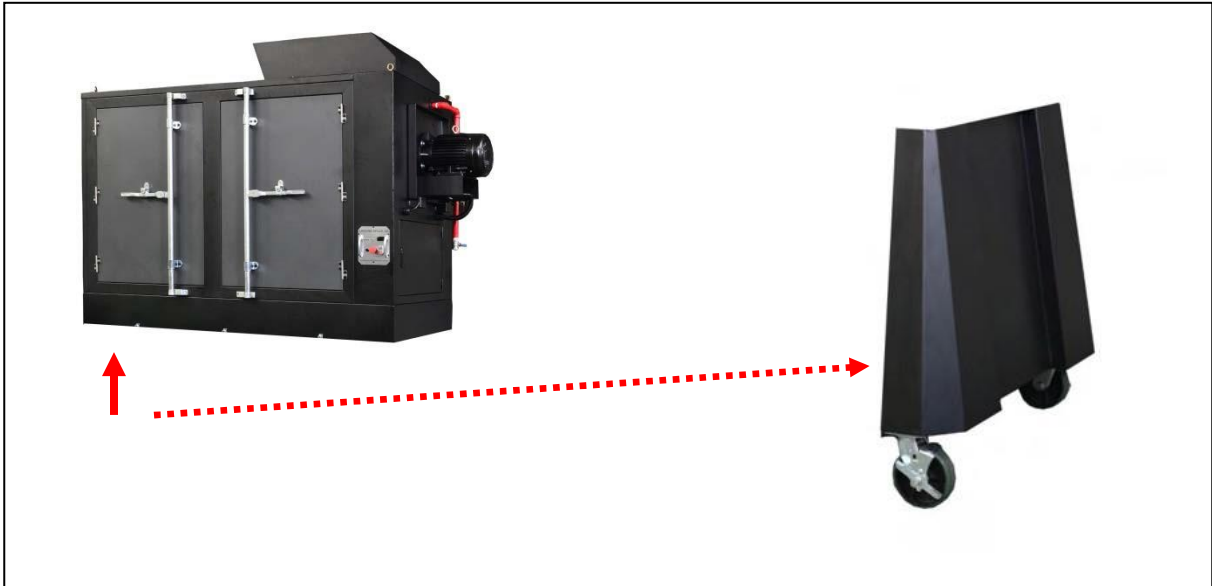

Step Four: Secure the latch base plate to the front side of the drum lid using (2) 3/16"x3/8" round head bolts.



LAGUNA

Step Five: Secure the casters to the drum base panel using (8) 3/8"x23x2 flat washers and (4) 3/8" nuts.



Step Six: Assemble the front and back panel to the drum base using (10) 5/16"x5/8" Philips hd bolts, (20) 5/16"x18x2 flat washers and (10) 5/16" nuts.



LAGUNA

Step Seven: Assemble the side panels to the drum using (6) 5/16"x5/8" Philips hd bolts, (12) 5/16x18x2 flat washers and (6) 5/16" nuts to secure the base. And then use (16) 5/16"x5/8" Philips hd bolts, (16) 5/16"x18x2 flat washers and (16) 5/16" nuts to secure the panels to each other.



Step Eight: Assemble the top rim to the panels using (11) 5/16"x5/8" Philips hd bolts, (11) 5/16"x18x2 flat washers and (11) 5/16" nuts.



LAGUNA

Step Nine: Assemble the latch to the drum using (4) 3/16"x3/8" round head thread bolts.

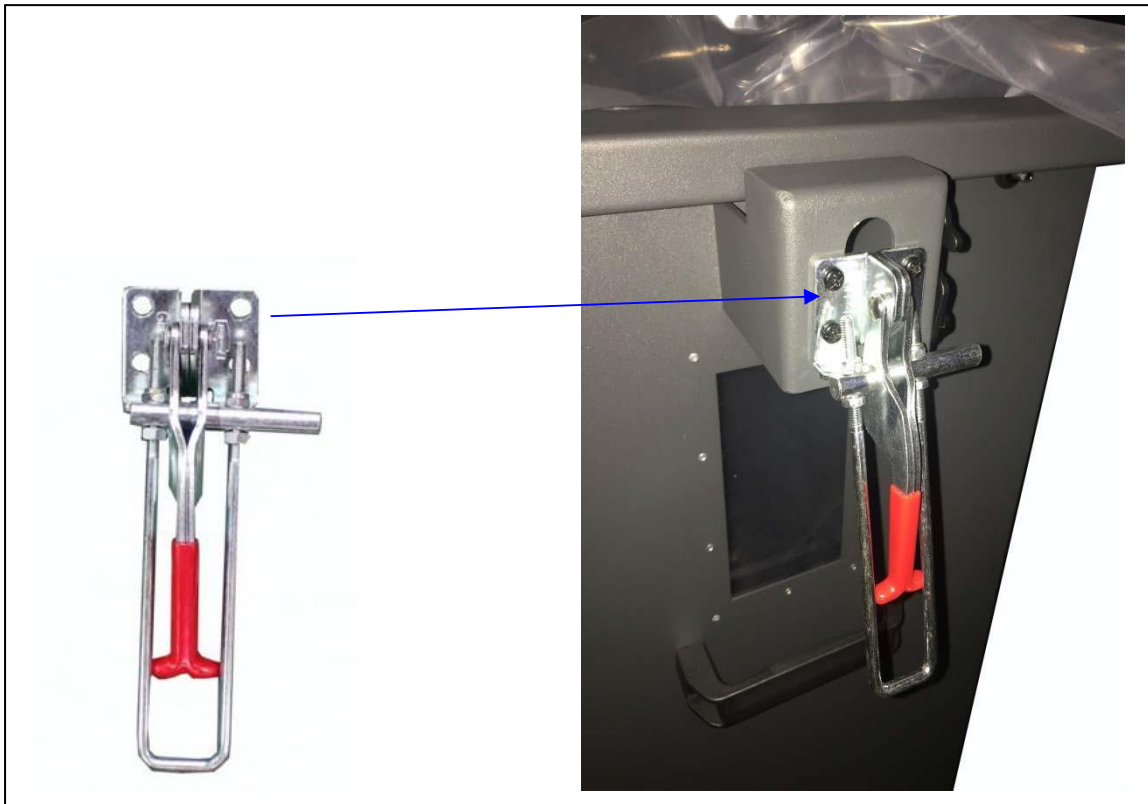

Step Ten: Attach the 2-1/2"x2M flex hose to the drum and drum lid. Do the same for the other two drums.



LAGUNA

Step Eleven: Place the vacuum suction ring inside before inserting the plastic bag in the Octagon drum.

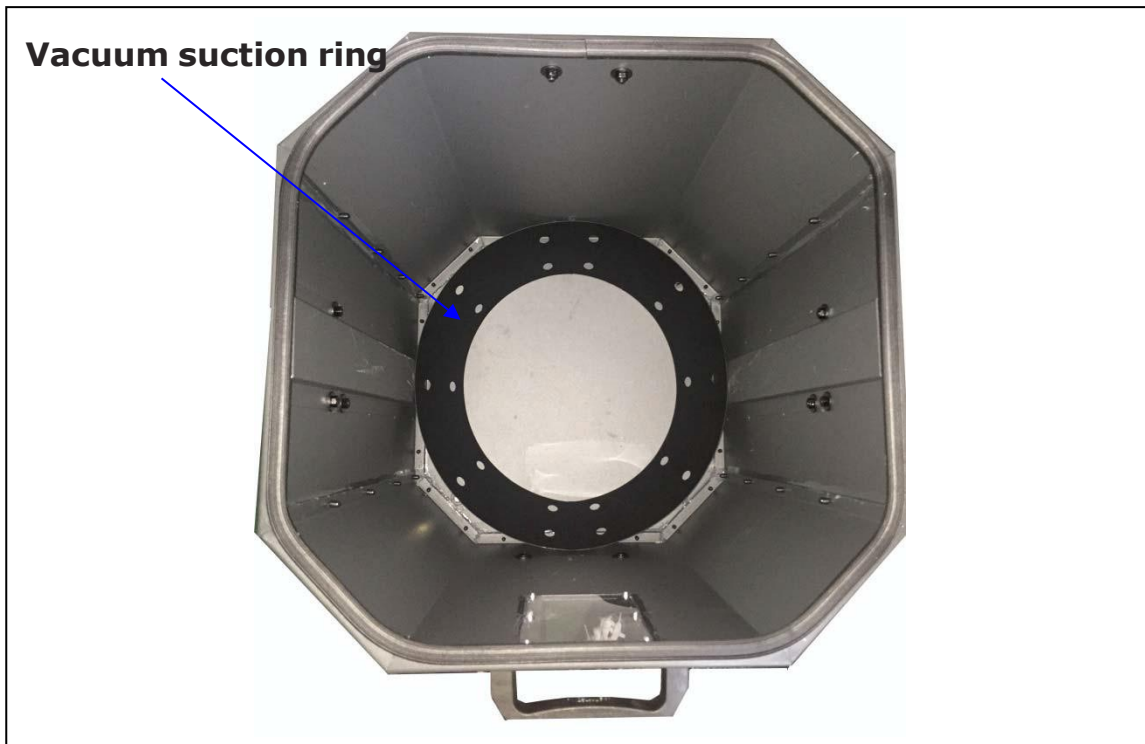

Step Twelve: Once completing the assembly, apply silicone to the inside of the drum including the base to seal and prevent air leakage.

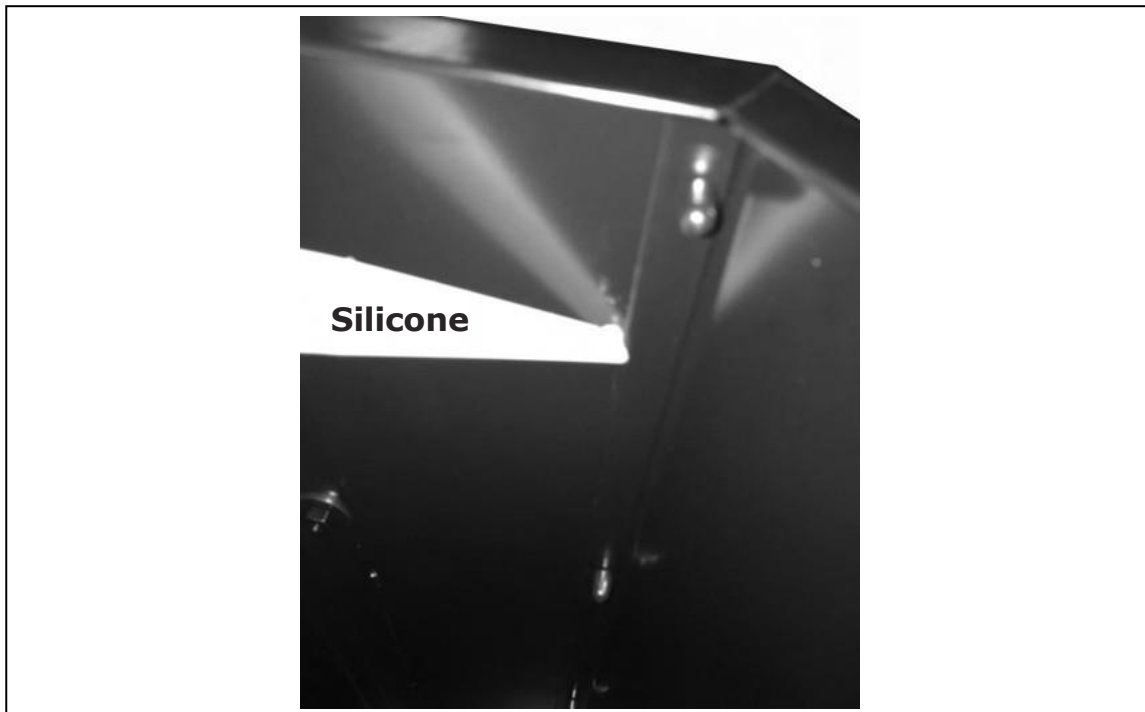

LAGUNA

Step Thirteen: Attach the 12" intake to the left side of the machine as shown below using (10) 5/16"x3/4" hex bolts and (10) 5/16"x18x2 flat washers.



Step Fourteen: All the assembly steps have been completed.



LAGUNA

CLEANING THE FILTER

To ensure proper operation of this Dust Cyclone, the canister filter must have adequate air flow. This means the filter must be regularly maintained by carefully blowing the filter clean using compressed air and an air gun to release built-up particulates trapped between the filter pleats.

For heavy duty users, it is recommended to use compressed air on a regular basis to maintain maximum filtration efficiency and longer life span of the filter.

Auto cleaning motor

The machine is equipped with an auto cleaning system that will clean the canister filter in an hourly interval for 10 seconds one way and another 10 seconds the other way. The cleaning will stop when you shut the machine off. While the canister is cleaning the LED light will illuminate showing that it is in the process of cleaning.

Using Compressed Air



DISCONNECT MACHINE FROM POWER!

For heavy duty users, it is recommended to use compressed air on a weekly basis to maintain maximum filtration efficiency and longer life span of the filter.

REMOVING THE CANISTER FILTER

1. Open the maintenance door on the canister cover plate sitting on top of the dust chute where the gear motor is located.

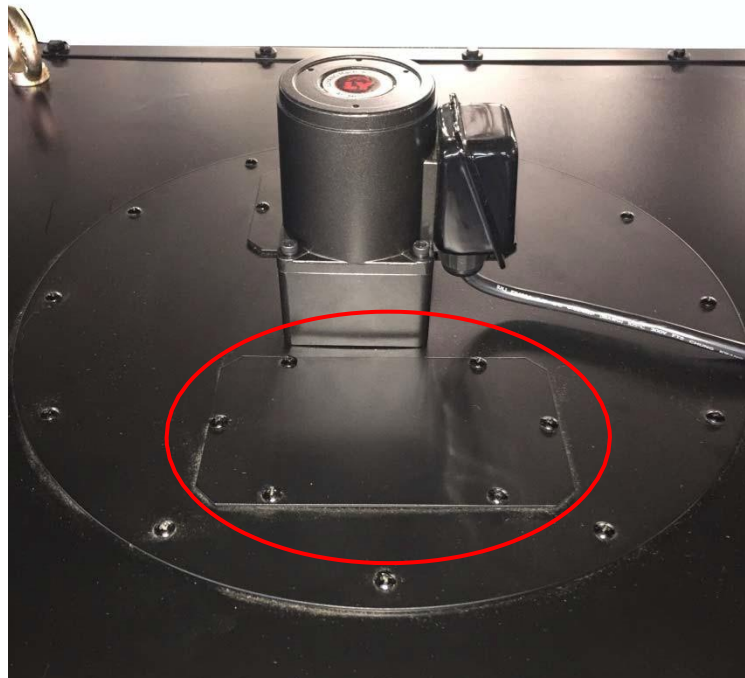

LAGUNA

2. Loosen the bolt and remove from the rotation shaft as shown below. Set the shaft aside for later use. Keep the bolt for use when reassembling the rotation shaft.

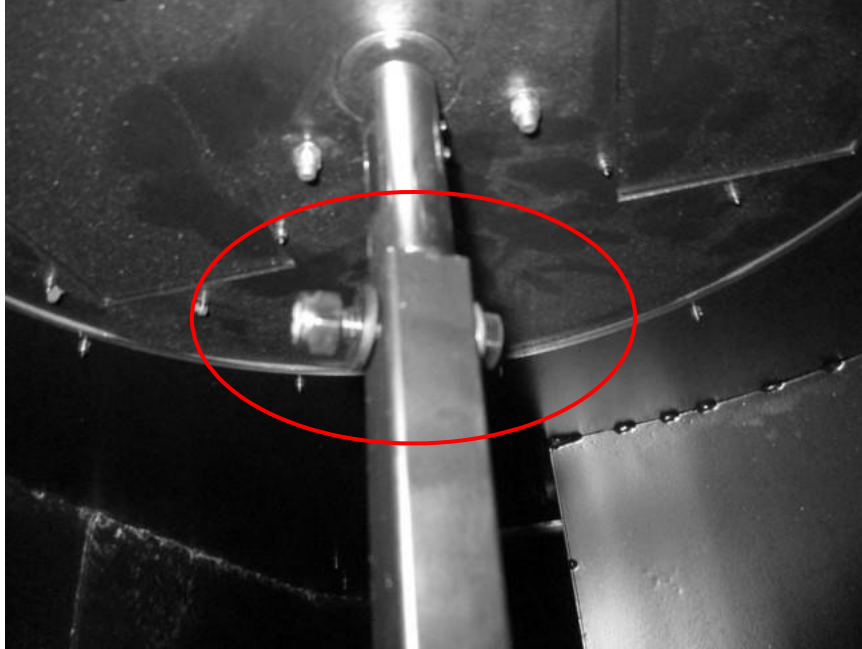

3. Remove the adjustable clamp from the canister filter located at the bottom to remove the canister filter from the housing.

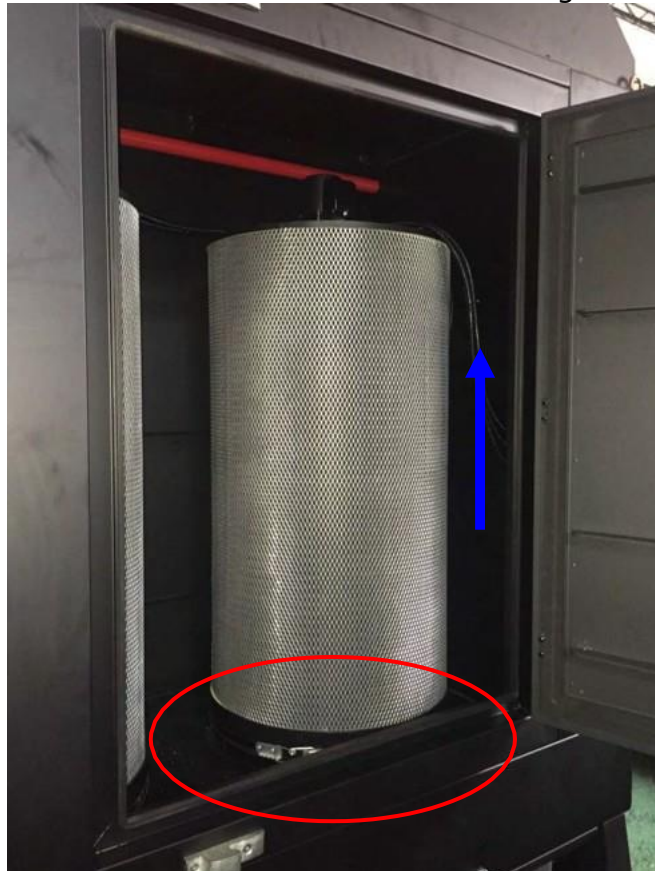

LAGUNA

4. With the canister filter removed use a compressed air gun to thoroughly clean between the pleats, both inside and outside.

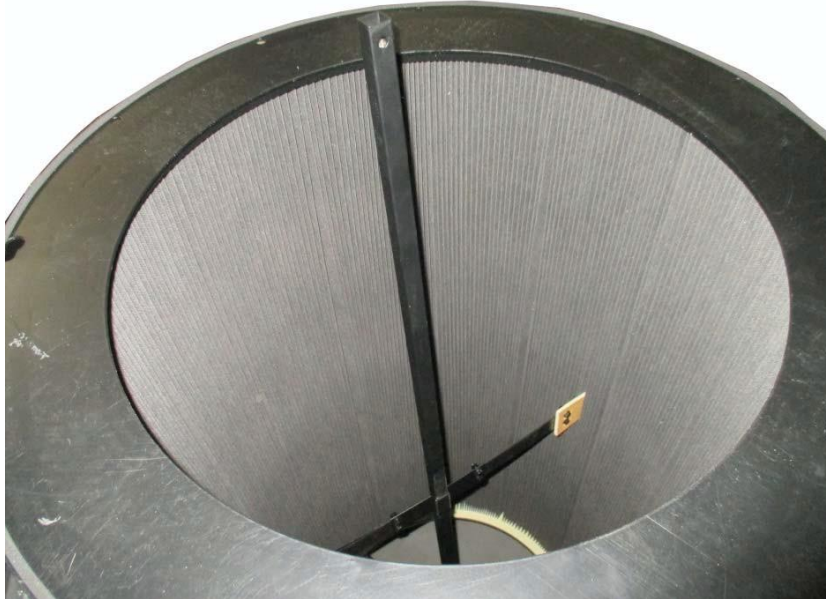

RE-ASSEMBLING THE CANISTER FILTER AFTER CLEANING

1. With the aid of another person, carefully re-insert the canister filter repeating steps above in reverse.

EMPTYING OR REPLACING THE FILTER BAG

Periodically check the filter bag, if it is more than one third full, it is recommended that you empty it.

NOTE: If the filter bag gets too full, the weight may force it to pull away from the band clamp, exposing the user to potentially harmful particulates.

1. Release the spring-loaded band clamp at the bottom of the filter and remove the filter bag.
2. Empty or replace the filter bag and re-attach using the spring-loaded band clamp.

EMPTYING THE DRUM

Periodically inspect the contents of the drum and empty as needed. To inspect the contents of the drum:

1. Lift the red hand on the latch on the drum lid to lower the drum.



2. Roll it away from the machine, inspect and empty as needed.

ROUTINE INSPECTION

It is a good idea to routinely inspect any quality woodworking tool to keep it in optimum condition. This includes inspecting all hardware for tightness, ensuring the filter is clean, and cleaning debris and grime from any surfaces and moving parts.



TROUBLESHOOTING GUIDE

Symptom	Possible Cause	Possible Solution
Machine does not start or a breaker trips.	Power supply switched OFF or is faulty.	Confirm power supply is ON and has the correct voltage.
	Wall fuse/circuit breaker is blown/tripped.	Ensure adequate circuit size; install inlet restrictor, replace weak breaker.
	Faulty remote control.	Replace batteries; ensure unobstructed line-of-sight and signal range.
	Remote receiver is faulty.	Inspect receiver circuit board; replace if faulty.
	Incorrectly wired motor connection.	Rewire or call certified service technician or electrician.
	On-board circuit breaker is tripped.	Allow motor to cool, improve ventilation, press reset button.
	Wiring is open/has high resistance.	Check for broken wires or poor connections, repair as necessary.
	Faulty power switch.	Replace switch.
Excessive vibration or noise during operation.	Motor is at fault.	Test/repair/replace.
	Loose component.	Inspect and tighten all bolts/nuts.
	Loose or broken motor mount.	Tighten or replace as needed.
	Motor fan hitting fan cover.	Check fan and cover; replace as needed.
	Bad motor bearings.	Rotate shaft manually, check for grinding or loose shaft, replace bearings if needed.

LAGUNA

<p>Loud, repetitive noise, or excessive vibration coming from cyclone</p>	<p>Machine is on uneven surface.</p> <p>Damaged/Unbalanced impeller.</p> <p>Loose connections.</p> <p>Impeller loose.</p> <p>Motor fan hitting fan cover.</p>	<p>Stabilize on a flat surface.</p> <p>Inspect impeller for dents, bends, loose fins. Replace it if needed.</p> <p>Check and re-tighten all fasteners.</p> <p>Replace the motor and impeller.</p> <p>Check fan and cover; replace as needed.</p>
<p>Dust cyclone does not adequately collect dust or chips; poor performance.</p>	<p>Canister end cap is full.</p> <p>Filter is dirty.</p> <p>Restricted duct line.</p> <p>Suction route is too long or has too many sharp bends.</p> <p>Wet lumber is clogging ducts.</p> <p>Leaks in the duct work or too many open ports.</p> <p>Inadequate velocity in the main suction line.</p> <p>Wrong size ducting/ports used.</p>	<p>Empty canister end cap.</p> <p>Clean filter.</p> <p>Clean inlet splitter.</p> <p>Move machine closer to the point of suction, and rerun ducts to eliminate sharp bends.</p> <p>Use lumber with less than 20% moisture content.</p> <p>Repair all duct leaks and close any ports not being used.</p> <p>Increase velocity by opening 1 or 2 more blast gates to different branch lines.</p> <p>Re-size and re-install ducts and fittings.</p>
<p>Sawdust being blown into the air from the dust cyclone</p>	<p>Band clamp or end cap is not secure.</p> <p>Loose or damaged seals.</p>	<p>Re-install ensuring a tight fit.</p> <p>Replace seals and gaskets.</p>

Parts Breakdown

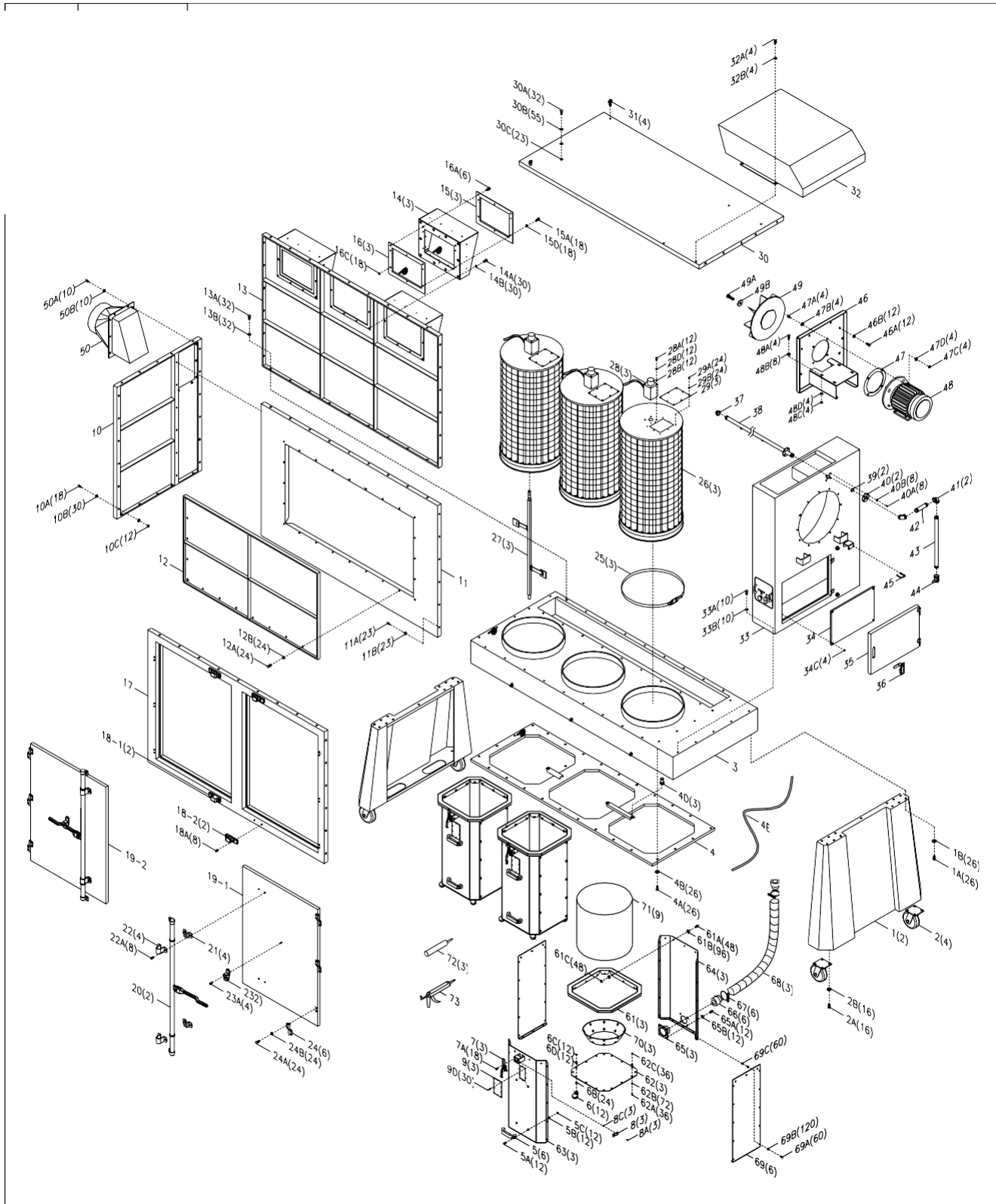

Part List

Ref No	Part Name	Description	QTY
1	UPRIGHT SUPPORT STAND		2
1A	HEX BOLT	3/8"*1"	26
1B	FLAT WASHER	3/8"*OD23*2t	26
2	MACHINE CASTER		4
2A	HEX BOLT	3/8"*1"	16
2B	FLAT WASHER	3/8"*OD23*2t	16
3	UPPER BODY		1
4	LOWER BODY		1
4A	HEX BOLT	3/8"*1"	26
4B	FLAT WASHER	3/8"*OD23*2t	26
4D	PROXIMITY SENSOR		3
4E	RUBBER SEAL	7M	1
5	HANDLE		6
5A	PHILIP HD BOLT	5/16"*3/4"	12
5B	FLAT WASHER	5/16"*OD23*2t	12
5C	NUT	5/16"	12
6	DRUM CASTER	2"	12
6B	FLAT WASHER	3/8"*OD23*2t	24
6C	HEX NUT	3/8"	12
6D	LOCK WASHER	3/8"	12
7	U-SHAPED HANDLE		3
7A	PHILIP HD BOLT	3/16"*3/8"	18
8	HANDLE SUPPORT CLIP		3
8A	HEX BOLT	1/4"	3

LAGUNA

Ref No	Part Name	Description	QTY
8C	HEX LOCK NUT	1/4"	3
9	WINDOW		3
9D	RIVET		30
10	MACHINE BODY – SIDE PANEL		1
10A	HEX BOLT	3/8"*1"	18
10B	FLAT WASHER	3/8"*OD23*2t	30
10C	HEX LOCK NUT	3/8"	12
11	MACHINE BODY – MIDDLE PANEL		1
11A	HEX BOLT	3/8"*1"	23
11B	FLAT WASHER	3/8"*OD23*2t	23
12	MIDDLE CONNECTOR PANEL		1
12A	HEX BOLT	3/8"*	24
12B	FLAT WASHER	3/8"*OD23*2t	24
13	MACHINE BODY – BACK PANEL		1
13A	HEX BOLT	3/8"*1"	32
13B	FLAT WASHER	3/8"*OD23*2t	32
14	SUPPRESSION VENT HOOD		3
14A	ROUND BOLT	3/8"*3/4"	30
14B	FLAT WASHER	3/8"*OD23*2t	30
15	SUPPRESSION VENT		3
15A	PHILIP HD BOLT	1/4"*5/8"	18
15D	LOCK WASHER	1/4"	18
16	SUPPRESSION VENT GASKET		3
16A	THREAD BOLT	5/16"*2-1/2"	6
16C	FLANGE NUT	1/4"	18
17	MACHINE BODY – FRONT PANEL		1

LAGUNA

Ref No	Part Name	Description	QTY
18-1	RIGHT SUPPORT BASE		2
18-2	LEFT SUPPORT BASE		2
18A	THREAD BOLT	5/16"*3/4"	8
19-1	RIGHT DOOR		1
19-2	LEFT DOOR		1
20	DOOR HANDLE		2
21	HINGE BASE – LOWER		4
22	HINGE BASE – TOP		4
22A	THREAD BOLT	5/16"*3/4"	8
23	HANDLE LATCH		2
23A	PHILIP HD BOLT	1/4"*5/8"	4
24	HINGE		6
24A	HEX BOLT	5/16"*3/4"	24
24B	FLAT WASHER	5/16"*OD18*2t	24
25	ADJUSTABLE CLAMP	Ø500	3
26	CANISTER FILTER	Ø510*900mm	3
27	ROTATION SHAFT		3
28	GEAR MOTOR		3
28A	ROUND HD BOLT	M5*65L	12
28D	LOCK WASHER	3/16"*3/16"	12
28B	FLAT WASHER	3/16"*OD12*1t	12
29	CANISTER MAINTENANCE DOOR		3
29A	PHILIP HD BOLT	3/16"*3/8"	24
29B	FLAT WASHER	3/16"*OD12*1t	24
30	MACHINE BODY TOP PANEL		1
30A	HEX BOLT	3/8"*1"	32

LAGUNA

Ref No	Part Name	Description	QTY
30B	FLAT WASHER	3/8"*OD23*2t	55
30C	HEX LOCK NUT	3/8"	23
31	RING	3/8"*1"	4
32	SILENCER		1
32A	HEX BOLT	5/16"*3/4"	4
32B	FLAT WASHER	5/16"*OD18*2t	4
33	DUST CHUTE		1
33A	HEX BOLT	3/8"*1"	10
33B	FLAT WASHER	3/8"*OD23*2t	10
34	CONTROL SUPPORT PLATE		1
34C	HEX NUT	1/4"	4
35	CONTROL BOX DOOR		1
36	HANDLE		1
37	NUT	1"	1
38	WATER HOSE-1	Ø1"*2225	1
39	RING		2
40	WATER HOSE COVER PLATE		2
40A	HEX BOLT	5/16"*3/4"	8
40B	FLAT WASHER	5/16"*OD18*2t	8
41	90DEGREE ELBOW	1"	2
42	WATER HOSE-2	Ø1"*160	1
43	WATER HOSE-3	Ø1"*850	1
44	VALVE	1"	1
45	U=SHAPED BOLT	1/4"	1
46	MOTOR SUPPORT BASE		1
46A	HEX BOLT	3/8"*1"	12

LAGUNA

Ref No	Part Name	Description	QTY
46B	FLAT WASHER	3/8"*OD23*2t	12
47	GASKET		1
47A	HEX BOLT	5/8"*2"	4
47B	FLAT WASHER	5/8"*OD40*2.5t	4
47C	HEX NUT	5/8"	4
47D	LOCK WASHER	5/8"	4
48	MOTOR	10HP/220V/3PHASE/60HZ	1
48A	HEX BOLT	1/2"*1-1/2"	4
48B	FLAT WASHER	1/2"*OD34*2.5t	8
48C	HEX NUT	1/2"	4
48D	LOCK WASHER	1/2"	4
49	IMPELLER	15.5"	1
49A	IMPELLER BOLT	M10*25	1
49B	IMPELLER SPECIAL WASHER	3/8"*3T _Ø 45	1
50	INTAKE – SQUARE TO ROUND	12"	1
50A	HEX BOLT	5/16"*3/4"	10
50B	FLAT WASHER	5/16"*OD18*2t	10
61	DRUM LID		3
61A	HEX BOLT	1/4"*5/8"	48
61B	FLAT WASHER	1/4"*OD18*2t	96
61C	LOCK NUT	1/4"	48
62	OCTAGON DRUM BASE PANEL		3
62A	HEX BOLT	1/4"*5/8"	36
62B	FLAT WASHER	1/4"*OD18*2t	72
62C	LOPCK NUT	1/4"	36
63	OCTAGON FRONT PANEL		3

LAGUNA

Ref No	Part Name	Description	QTY
64	OCTAGON DRUM BACK PANEL		3
65	DRUM VACUUM TUBE		3
65A	PHILIP HD BOLT	1/4"*5/8"	12
65B	FLAT WASHER	1/4"*OD18*2t	12
66	HOSE CONNECTOR		6
67	HOSE CLAMP	2-1/2"	6
68	GRAY FLEX HOSE	2-1/2"*2M	3
69	OCTAGON DRUM SIDE PANEL		6
69A	HEX BOLT	1/4"*5/8"	60
69B	FLAT WASHER	1/4"*OD18*2t	120
69C	LOCK NUT	1/4"	60
70	VACUUM SUCTION PLATE		3
71	COLLECTION DRUM PLASTIC BAG		9
72	GENERAL PURPOSE SEALANT		3
73	SILCONE GUN		1

WARRANTY & REGISTRATION

Thank You!

Welcome to the Laguna Tools® group of discriminating machinery owners. We understand that you have a choice of where to purchase your machines and appreciate the confidence you have in the Laguna Tools® brand.

Through hands-on experience, Laguna Tools® is constantly working hard to make innovative, precision products. Products that inspire you to create works of art are a joy to operate and encourage your best work.

Laguna Tools®
Imagination, Innovation, and Invention at Work

Warranty & Registration

Every product sold is warranted to be free of manufacturer's defective workmanship, parts, and materials. For any questions about this produce, the intended use or what it was designed for, customer service, or replacement parts, please contact our customer service department:

Laguna Tools® Customer Service
744 Refuge Way, Grand Prairie, Texas 75050, USA
1-800-234-1976
customerservice@lagunatools.com
www.lagunatools.com/why/customer-service/
8AM. To 5PM PSF. Monday through Friday

For warranty claims or to report damage upon receiving-please reach out to our warranty department:

Laguna Tools® Warranty Service
744 Refuge Way, Grand Prairie, Texas 75050, USA
1-800-234-1976
customerservice@lagunatools.com
www.lagunatools.com/policies/warranty
8AM to 5PM PST, Monday through Friday

Registration

To prevent voiding this warranty, all products sold must be registered within thirty (30) days of receiving the product. Registering the product will enable the original purchaser to receive notifications about important product changes, receive customer service, and be able to file a warranty claim against defective workmanship, parts, or materials.



Who is Covered

The applicable warranty covers only the initial purchaser of the product from the date of receiving the product. To file such claims, the original purchaser must present the original receipt as proof of purchase.

What is Covered

The warranty covers any defects in the workmanship of all parts and materials that make up the machine unless otherwise specified. Any part determined by Laguna Tools® to have a defect will be repaired or replaced (and shipped), without charge. The defective item/part must be returned to Laguna Tools® with the complaint and proof of purchase in the original packaging that it was received in. In the event the item/part is determined to be not covered by this warranty, the customer will be responsible for the cost to replace the item/part and all related shipping charges

Warranty Limitations

This limited warranty does not apply to natural disasters, acts of terrorism, normal wear and tear, product failure due to lack of maintenance or cleaning, damage caused by accident, neglect, or lack-of inadequate dust collection. The warranty may be voided against proof of misuse/abuse, damage caused where repair or alterations have been made or attempted by others, using the product for purposes other than those described as intended use (unless with consent by Laguna Tools®), modification to the product, or use with an accessory that was not designed for the product. It is the responsibility of the user to understand basic machinery settings and procedures and to properly maintain the equipment in accordance with the standards provided in this manual.

Length of Warranty

All new machines and optional accessories sold through an authorized dealer carry a two-year warranty effective from the date of receiving the product. Machines sold for either commercial or industrial use have a one-year warranty. Wearable parts like throat plates, bandsaw guides, etc., have a ninety-day warranty.

Table A-1 Warranty Lengths

2 Year – New Machines Sold Through an Authorized Dealer
2 Year – Accessories Sold as Machine Options (excluding blades)
1 Year – Machines Sold for Commercial or Industrial Use
1 Year – Blades and Accessories outside or Machine Options
90 Days – Wearable Parts

Aside from being free of defects upon receiving, consumable parts, like cutters and abrasives, are not covered by this warranty unless otherwise stated by Laguna Tools®. These parts are designed to be used at the expense of the operator and are available for replacement or inventory purchase. The determination of a consumable part will be made on a case-by-case basis by Laguna Tools®.

Shipping Damage

Laguna Tools® is not responsible for damage or loss caused by a freight company or other circumstances not in the direct control of Laguna Tools®. All shipping-related claims for loss or damage to goods must be made to Laguna Tools® within twenty-four hours of delivery.

How to Receive Support

To file a warranty-claim please contact the warranty department at 1-800-234-1976. To receive customer service or technical support please contact the customer service or technical support please contact the customer service department at 1-800-332-4094. Parts, under warranty, are shipped at the expense of Laguna Tools® either by common carrier, FedEx ground services or similar method. Technical support to install replacement parts is primarily provided by phone, fax, email, or the Laguna Tools® Customer Service Support Website.



© 05/2023 Laguna Tools, Inc.



744 Refuge Way Suite 200
Grand Prairie TX 75050

Ph: 800.234.1976 | www.lagunatools.com

Laguna Tools is not responsible for errors or omissions.
Specifications subject to change. Machines may be shown with optional accessories.

© 2018, Laguna Tools, Inc. LAGUNA® and the LAGUNA Logo® are the
registered trademarks of Laguna Tools, Inc. All rights reserved.

051223