

E|FLUX:7

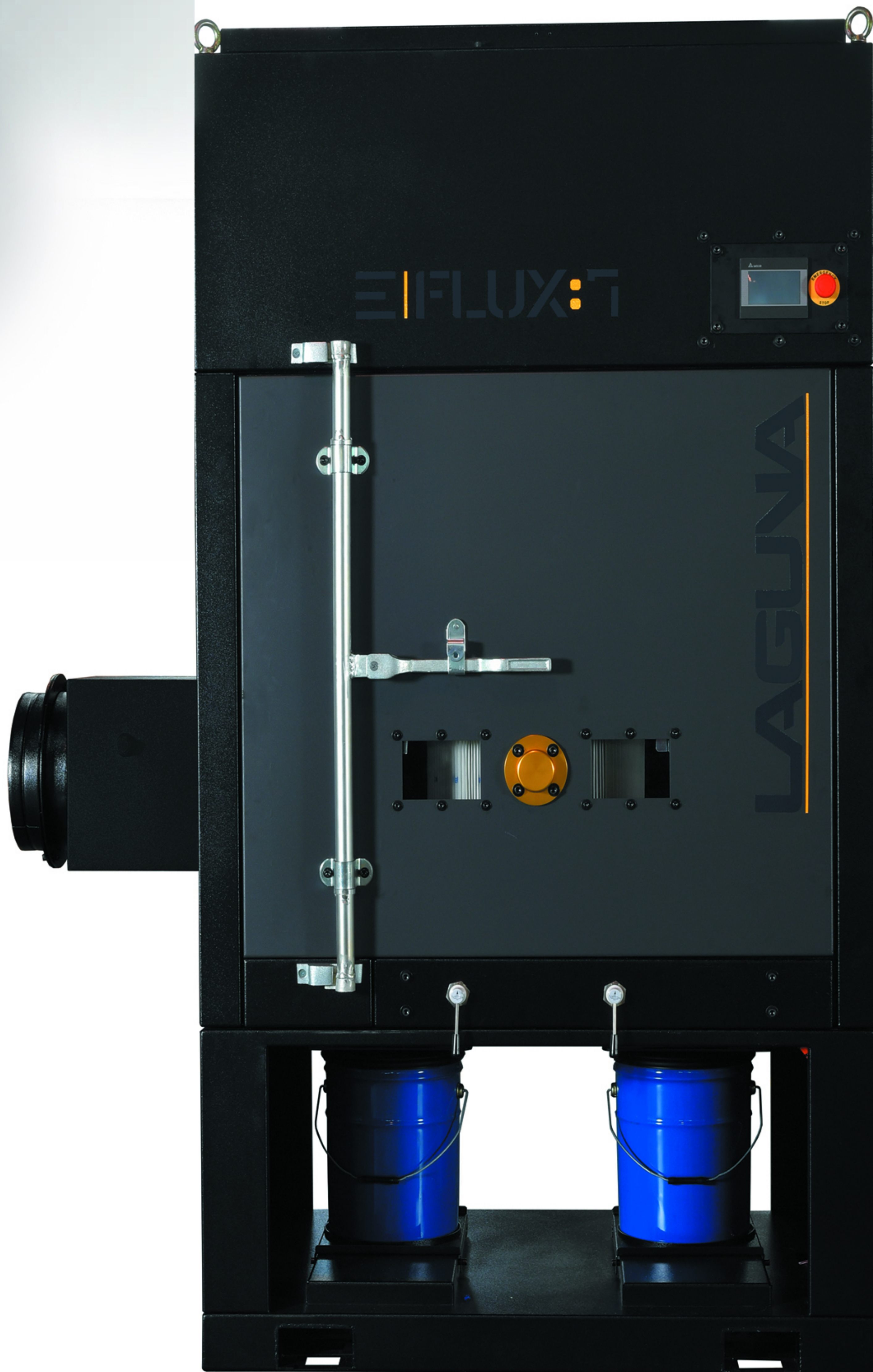

7.5HP EXPLOSION-PROOF
FOR LASER CUTTING CLEAN AIR SYSTEM

LAGUNA

Contents

Introduction3

Important Safety Measures

Assembly instructions..... 4

General safety rules..... 4

Dust collector fire hazard safety rules..... 4

Safety rules for operation..... 5

Handling, transportation and Installation 6

Operation instructions..... 6

Repair and Maintenance instructions..... 7

Assembly and Parts..... 8

SF-75LSD Explanation of touch screen..... 10~11

 1. Screen display during operation..... 12~13

 2. Screen display description..... 14

 3. Screen display for emergency..... 15~17

 4. Alarm List..... 18

 5. Parameter settings..... 19~20

 6. Emergency stop..... 20

Machine Start up and Stop..... 21~23

Canister filter maintenance..... 24~25

Collection drum maintenance..... 26~29

Regular check table..... 30~31

Trouble shooting..... 32~33

INTRODUCTION

The toxic air pollution and san dust produced by laser cutting machines affect the health of workers a great deal, also causing environmental pollution. This dust collector is specialized for the use with laser cutting machines. With its highly efficient dust and smoke extraction it will prevent any further secondary pollution in your working environment.

The quality and build on this machine is guaranteed for near perfect functioning. However, if a situation arises, refer to the manual first. If a solution cannot be found, please contact the distributor where you purchased our product. Please have the serial number of the machine (Stamped on the nameplate). For any replacement parts, please refer to the assembly drawing and parts list in this manual.

Laguna Tools staff will do their best to help you get your machine in working order.

IMPORTANT SAFETY INSTRUCTIONS



READ AND UNDERSTAND ALL WARNINGS AND OPERATING INSTRUCTIONS BEFORE USING THIS MACHINE Failure to follow all instructions listed below, may result in electric shock, fire, and/or serious personal injury or property damage.



This machine was designed for certain applications only. We strongly recommend that this machine not be modified and/or used for any application other than that for which it was designed. If you have any questions relative to a particular application, DO NOT use the machine until you have first contacted the distributor where you purchased this machine from to determine if it can or should be performed on the product.

When using this machine, basic precautions should always be followed, including the following:

READ ALL INSTRUCTIONS BEFORE USING THIS MACHINE.**▲WARNING**

To reduce the risk of fire, electric shock, or injury:

1. Do not leave this machine when plugged in. Unplug from outlet when not in use and before servicing.
2. Do not use outdoors or on wet surfaces
3. Do not allow to be used as a toy. Close attention is necessary when used by or near children.
4. Use only as described in this manual. Use only distributor's recommended attachments.
5. Do not use with damaged cord or plug.
6. Do not pull or carry by cord, use cord as a handle, close a door on cord, or pull cord around sharp edges or corners. Do not run machine over cord. Keep cord away from heated surfaces.
7. Do not put any object into openings. Do not use with any opening blocked; keep free of dust, lint, hair, and anything that may reduce air flow.
8. Keep hair, loose clothing, fingers, and all parts of body away from openings and moving parts.
9. Do not use to pick up flammable or combustible liquids, such as gasoline, or use in areas where they may be present.
10. Connect to a properly grounded outlet only. See Grounding Instructions.

SAVE THESE INSTRUCTIONS

1. Read and understand the warnings posted on the machine and in this manual. Failure to comply with all of these warnings may cause serious injury.
2. Replace the warning labels if they become obscured or removed.
3. This machine is designed and intended for use by properly trained and experienced personnel only. If you are not familiar with the proper and safe operation of this type of machine, do not use until proper training and knowledge have been obtained.
4. Do not use this machine for other than its intended use. If used for other purposes, **LAGUNA TOOLS INC.**, disclaims any real or implied warranty and holds itself harmless from any injury that may result from that use.
5. Always wear approved safety glasses/face shields while using this machine.
6. Before operating this machine, remove tie, rings, watches and other jewelry, and roll sleeves up past the elbows. Remove all loose clothing and confine long hair. Non-slip footwear or anti-skid floor strips are recommended. Do **not** wear gloves.
7. Wear ear protectors (plugs or muffs) during extended periods of operation.

8. Do not operate this machine while tired or under the influence of drugs, alcohol or any medication.
9. Make certain the switch is in the **OFF** position before connecting the machine to the power source.
10. Make certain the machine is properly grounded.
11. Make all machine adjustments or maintenance with the machine unplugged from the power source.
12. Form a habit of checking to see that all extra equipment such as adjusting keys, wrenches, scrap, stock, and cleaning rags are removed away from the machine before turning on.
13. Keep safety guards in place at all times when the machine is in use. If removed for maintenance purposes, use extreme caution and replace the guards immediately when maintenance is complete.
14. Make sure this machine is on a flat even surface before use.
15. Check damaged parts. Before further use of the machine, a guard or other part that is damaged should be carefully checked to determine that it will operate properly and perform its intended function. Check for alignment of moving parts, binding of moving parts, breakage of parts, mounting and any other conditions that may affect its operation. A guard or other part that is damaged should be properly repaired or replaced.
16. Provide for adequate space surrounding work area and non-glare, overhead lighting.
17. Keep the floor around the machine clean and free of scrap material, oil and grease.
18. Keep visitors a safe distance from the work area. **Keep children away.**
19. Make your workshop child proof with padlocks, master switches or by removing starter keys.
20. Give your work undivided attention. Looking around, carrying on a conversation and "horse-play" are careless acts that can result in serious injury.
21. Maintain a balanced stance at all times so that you do not fall or lean against the dust collector. Do not overreach or use excessive force to perform any machine operation.
22. Use the right tool at the correct speed and feed rate. Do not force a tool or attachment to do a job for which it was not designed. The right tool will do the job better and safer.
23. Use recommended accessories; improper accessories may be hazardous.
24. Maintain machinery with care. Follow instructions for lubricating and changing accessories.

25. Turn off the machine before cleaning. Use a brush or compressed air to remove dust or debris — do not use your hands.
26. Do not stand on the machine. Serious injury could occur if the machine tips over.
27. Never leave the machine running unattended. Turn the power off and do not leave the machine until it comes to a complete stop.
28. Never operate or run the machine without closing the drum up against the lid. Failure to do so will result in the machine amperage increasing and may trip your circuit.

Familiarize yourself with the following safety notices used in this manual:

SAFETY GUIDELINES - DEFINITIONS

This manual contains information that is important for you to know and understand. This information relates to protecting YOUR SAFETY and PREVENTING EQUIPMENT PROBLEMS. To help you recognize this information, we use the symbols below. Please read the manual and pay attention to these sections.



DANGER Indicates an imminently hazardous situation which, if not avoided, will result in death or serious injury.



WARNING Indicates a potentially hazardous situation which, if not avoided, could result in death or serious injury.



CAUTION Indicates a potentially hazardous situation which, if not avoided, may result in minor or moderate injury.



CAUTION Used without the safety alert symbol indicates potentially hazardous situation which, if not avoided, may result in property damage.

GENERAL SAFETY RULES



WARNING FAILURE TO FOLLOW THESE RULES MAY RESULT IN SERIOUS PERSONAL INJURY.

FOR YOUR OWN SAFETY, READ AND UNDERSTAND THE INSTRUCTION MANUAL BEFORE OPERATING THE MACHINE. Learn the unit's application and limitations as well as the specific hazards peculiar to it.

KEEP WORK AREA CLEAN. Cluttered areas and benches invite accidents.

DON'T USE IN DANGEROUS ENVIRONMENT. Don't use this unit in damp or wet locations, or expose it to rain. Keep work area well-lighted.

KEEP CHILDREN AND VISITORS AWAY. All children and visitors should be kept a safe distance from work area.

DISCONNECT UNIT before servicing.

CHECK DAMAGED PARTS. Before further use of the unit, properly repair or replace any part that is damaged.

ADDITIONAL SAFETY

Intended use. This machine is only intended for collecting fumes and small metal dust and chips from woodworking machines. Do not use this machine to collect dirt, pebbles, drywall, asbestos, lead paint, silica, liquids, aerosols, or any flammable, combustible, or hazardous materials.

Hazardous dust. Dust created while using machinery may cause cancer, birth defects, or long-term respiratory damage. Be aware of dust hazards associated with each work piece material, and always wear a NIOSH-approved respirator to reduce your risk.

Wear respirator. Fine dust that is too small to be caught in the filter will be blown into the ambient air during operation. Always wear a NIOSH-approved respirator during operation and for a short time after to reduce your risk of permanent respiratory damage.

Emptying dust. When emptying dust from the collection drum, wear a respirator and safety glasses. Empty dust away from ignition sources and into an approved container.

Disconnecting power supply. Turn the switch off, disconnect this machine from the power supply, and allow the impeller to come to a complete stop before leaving the machine unattended or doing any service, cleaning, maintenance, or adjustments.

Suspended dust particles and ignition sources. Do not operate the machine in areas where explosion risks are high. Areas of high risk include, but are not limited to, areas near pilot lights, open flames, or other ignition sources.

Fire suppression. Only operate the machine in locations that contain a fire suppression system or have a fire extinguisher nearby.

Impeller hazards. Do not place your hands or tools near the open inlet during operation for any reason. The powerful suction could easily cause accidental contact with the impeller, which will cause serious personal injury or damage to the machine. Always keep small animals and children away from open dust collection inlets.

Avoiding sparks. Do not allow steel or rocks to strike the impeller—this may produce sparks. Sparks can smolder in wood dust for a long time before a fire is detected. If you accidentally cut into wood containing tramp metal (nails, staples, spikes, etc.), immediately turn **off** the machine, disconnect it from power, and wait for the impeller to stop—then empty the collection drum into an approved airtight metal container.

Operating location. To reduce respiratory exposure to fine dust, locate permanently installed machines away from the working area, or in another room that is equipped with a smoke detector. Do not operate the machine in rainy or wet locations—exposure to water may create a shock hazard or decrease the life of the machine.

Static electricity. Plastic dust lines generate high amounts of static electricity as dust chips pass through them. Although rare, sparks caused by static electricity can cause explosions or fire. To reduce this risk, make sure all dust lines are thoroughly grounded by using a grounding wire.

Regular cleaning. Regularly check/empty the collection bags or drum to avoid the buildup of fine dust that can increase the risk of fire. Make sure to regularly clean the surrounding area where the machine is operated—excessive dust buildup on overhead lights, heaters, electrical panels, or other heat sources will increase the risk of fire.

⚠ CAUTION

This means that if precautions are not heeded, it may result in minor injury and/or possible machine damage.

⚠ WARNING

This means that if precautions are not heeded, it may result in serious injury or possibly even death.

**SAVE THESE INSTRUCTIONS.
Refer to them often and use them to instruct others.**

■ Assembly guidelines

1. Install this machine on level ground to prevent any vibration or tipping over issues.
2. When lifting the machine, ensure to use the four eyebolts located on the top four corners of the unit.
3. Use metal ducts with this unit, minimize the angles in the duct to prevent air loss. Make sure the duct is secure and fastened properly.
4. You must use the same voltage as what is shown on the name plate and motor plate.
5. Do not replace any electrical components by yourself. The electrical components are customized to each machine and any changes or different parts will cause malfunction.
6. You will need to connect compressed air and nitrogen to this machine.
7. The pressure setting required for the compressed air at 4kg/cm²(57psi).
8. The pressure setting required for the Nitrogen is at 8kg/cm²(114psi).



DO NOT CONNECT THIS MACHINE TO THE POWER SOURCE OR SWITCH IT ON BEFORE IT IS FULLY ASSEMBLED. READ THIS MANUAL CAREFULLY BEFORE OPERATING THIS MACHINE.

■ ATTENTION

1. This machine was designed to extract the fumes from laser cutting machines.
2. DO NOT use this machine to extract or collect dust or gases; as this will cause for rusting, explosion or fire hazards.
3. DO NOT let any cigarette butts or any form of flammable gases from being collected by this machine. °
4. Empty the collection drums on a daily basis to prevent any fire hazard or cause damage to the canister filters.
5. The Nitrogen pressure must be kept at 8kg/cm²(114psi). You must check for sufficient Nitrogen supply on a regular basis.
6. This machine must be grounded to prevent any shock hazards.
7. DO NOT pour or add water into this machine.
8. Clean the HEPA filters on a regular basis to maintain the peak performance of this dust collector.

■ FIRE PRECAUTIONS

1. Understand the possible reasons for fire on this machine and take the necessary measures to troubleshoot and put out the fire.
2. DO NOT let this machine extract or collect the following materials or substances:
 - Flammable substances;
 - Explosive substances;
 - Fire source, such as cigarette butts
 - Other harmful substances (such as oil)



Important Safeguards

Before using our product, make sure you thoroughly understand the details of this manual properly for correct use. Precautions indicated here are designed for the prevention of harm or damage to yourself and or others. ◦

In the case of details that are described in (CAUTION) column, there is a possibility that those may cause serious consequence depending on circumstances.

In either case, these are important details regarding safety, therefore, be sure to observe them.

**DANGER**

DANGER Great risk of death or serious injury from improper use.

**WARNING**

WARNING Possibility of death or serious injury from improper use.

**CAUTION**

CAUTION Possibility of injury or damage to property from improper use.

**CAUTION**

Periodically clean the machine; to prevent the danger of a fire occurring ◦

■ Cautions in using this machine













**CAUTION**

Do not use this machine for any application other than predetermined machine specification ◦ It may cause ground fault, electric shock, explosion, fire, etc.















Use the machine approved by us only ◦





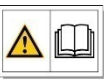



■ **Cautions in carrying-in/moving/installing this machine**

 CAUTION	
 <p>At the occasion of carrying-in or moving, work shall be performed in consideration of gravity and weight. *May cause injury due to drop, breakage, etc.</p>	 <p>At the occasion of transferring this machine by means of lift or traveling crane, the holder of respective license shall perform the transfer. *May cause injury due to fall, rollover, etc.</p>
 <p>In the instance of installing this machine at high elevations or installing hopper, secure stable scaffolding before work to ascertain safety. *May cause injury due to fall, rollover, etc.</p>	 <p>Do not make modification to this product nor try to relocate it without our prior written approval.</p>
 <p>This machine must be installed on a level surface with sufficient strength to hold the full weight of this machine.</p>	 <p>The electrical wiring of the machine must be conducted by a licensed technician. *Any incorrect wiring will cause for error and malfunction and even electric shock or death.</p>
 <p>Establish a proper grounding. *Without proper grounding, operators may receive electric shocks resulting from a malfunction or current leakage</p>	 <p>Do not position this machine near a flammable or explosive source; such as gasoline, paraffin, paint thinner or benzene paint. * These sources are highly explosive hazards and must be avoided.</p>
 <p>Do not allow this machine to extract or collect sparks or flammable sources *This will result in fire hazard.</p>	 <p>Do not allow this machine to extractor collect corrosive power or gases. *This will result in malfunction or electric shock or damage to this machine.</p>
 <p>Do not operate this machine in a humid atmosphere. *This will result in electric shock.</p>	 <p>Do not continue to operate this machine when there is a malfunction. *This will damage the machine.</p>

■ **Cautions in operating this machine**

 CAUTION	
<p>Do not allow for the following instances on the cables and cords:</p>  <ul style="list-style-type: none"> ● Heavy objects on top ● Common power source with other machines  <ul style="list-style-type: none"> ● Damage or separate them ● Bend or twist them  <ul style="list-style-type: none"> ● Pull or bundle together ● Lay across the floor of a working space. <p>*This will result in damage to the power source, cables and cause electric shock, explosion or fire.</p>	<p> Before operating this machine, ensure no person is nearby or in a dangerous zone. *This is result in injury and even death.</p> <p> Do not position this machine outside that can be exposed to rain. *This will result in electric shock, explosion or fire.</p> <p> Do not insert your hands, fingers or legs and feet into the inlet/intake. *This will result in serious injury and even death.</p>
<p> Do not use this machine in high temperatures over 40 degrees Celsius *This will result in fire.</p>	<p> Do not touch any parts or surfaces of the machine during operation. *This will result in serious injury or even death.</p>
<p> Do not use any voltage on this machine other than specified on the nameplate. *This will result in electric shock or short circuit or fire.</p>	<p> In case of emergency, stop the machine immediately and switch off the power source.</p>
<p> Use this machine only after you have fully ready and understand this manual.</p>	<p> When this machine has been connected, you must operate according to the manual provided.</p>

■ **Repair and safety inspection**

 CAUTION	
 <p>When this machine is under repair or maintenance, read this manual carefully and fully understand all the danger zones and safety measures required to prevent serious injury or even death.</p>	  <p>When this machine is under repair or maintenance, use the protective gear (gloves, masks and goggles.) to prevent serious injury.</p>
 <p>Cut the power source in case of emergency that is life threatening, electric shock or injury.</p>	 <p>Only have fully trained staff operate this machine to prevent any hazards, damage or injuries.</p>
 <p>In the instance of installing this machine at high elevations or installing hopper, secure stable scaffolding before work to ascertain safety. *May cause injury due to fall, rollover, etc.</p>	 <p>Attention, prevent any static on this machine to avoid electric shock or fire hazards.</p>

EFLUX7 Laser Cutting Dust Collector

PRODUCT SPECIFICATIONS

Motor Specs:	7.5 HP
Electrical Specs:	220V / 60Hz / 3PH / 3450 RPM
Running AMP	(with 12" inlet) 25A at 220V, 12.5A at 440V
Air Volume:	3628CFM (cubic feet per minute)
Inlet:	Ø12"
Fan:	Ø18"
Switch	PLC inverter control system
Collection capacity	5 gallon Octagon drum X 2
Packing Size:	55.9" x 41.3" x 100.4"
(L x W x H)	(142 x 105 x 255 cm)
Machine weight	1711 lbs (776kgs)

<u>Filter Media</u>	filtering area: 42 m2 (452.1 ft2)
Cartridge Filter	1 Micron Ø7.87" x 21.46" (Ø200 x 545mm) x 12pcs

EFLUX7 Laser Cutting Dust Collector

POWER CONNECTIONS

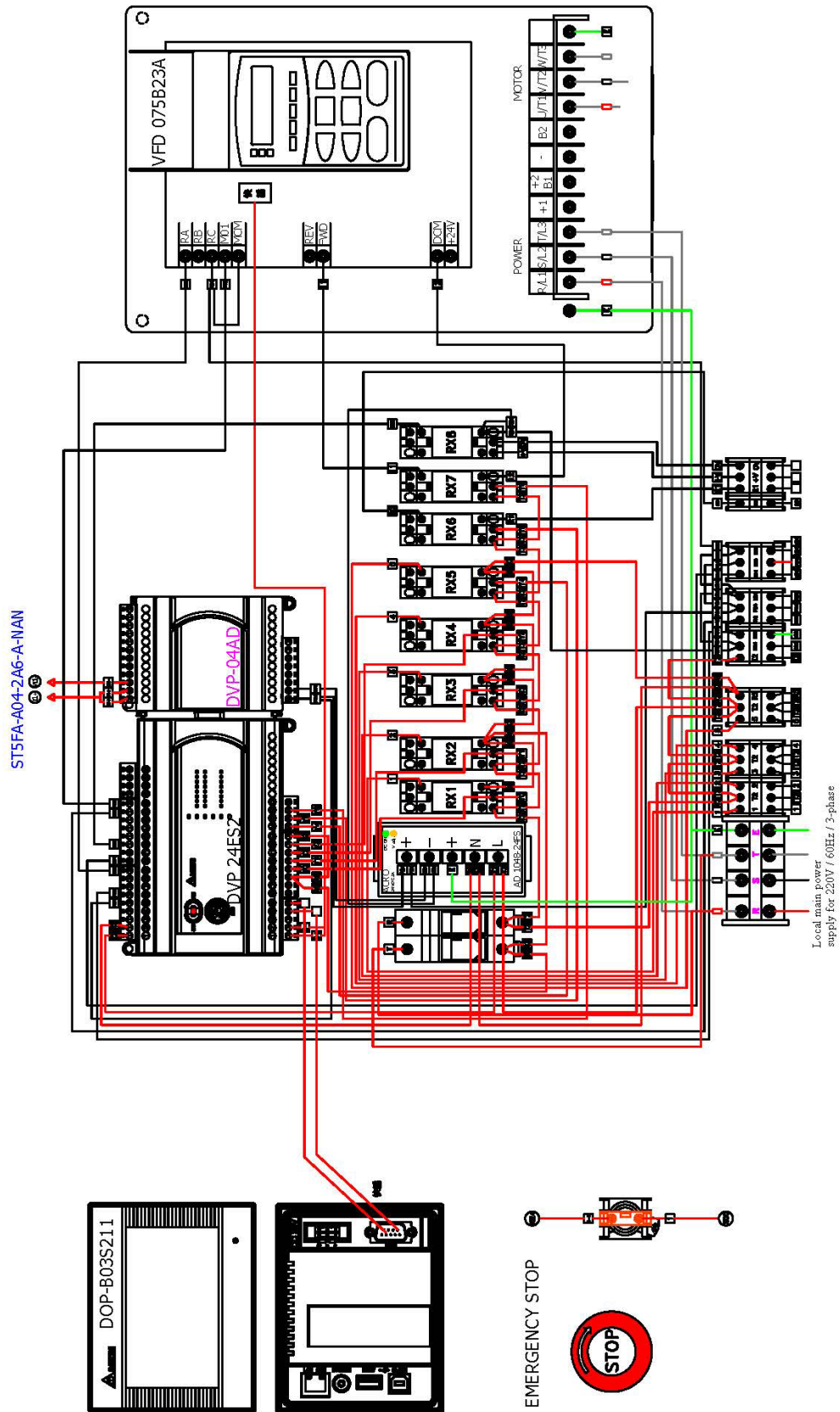

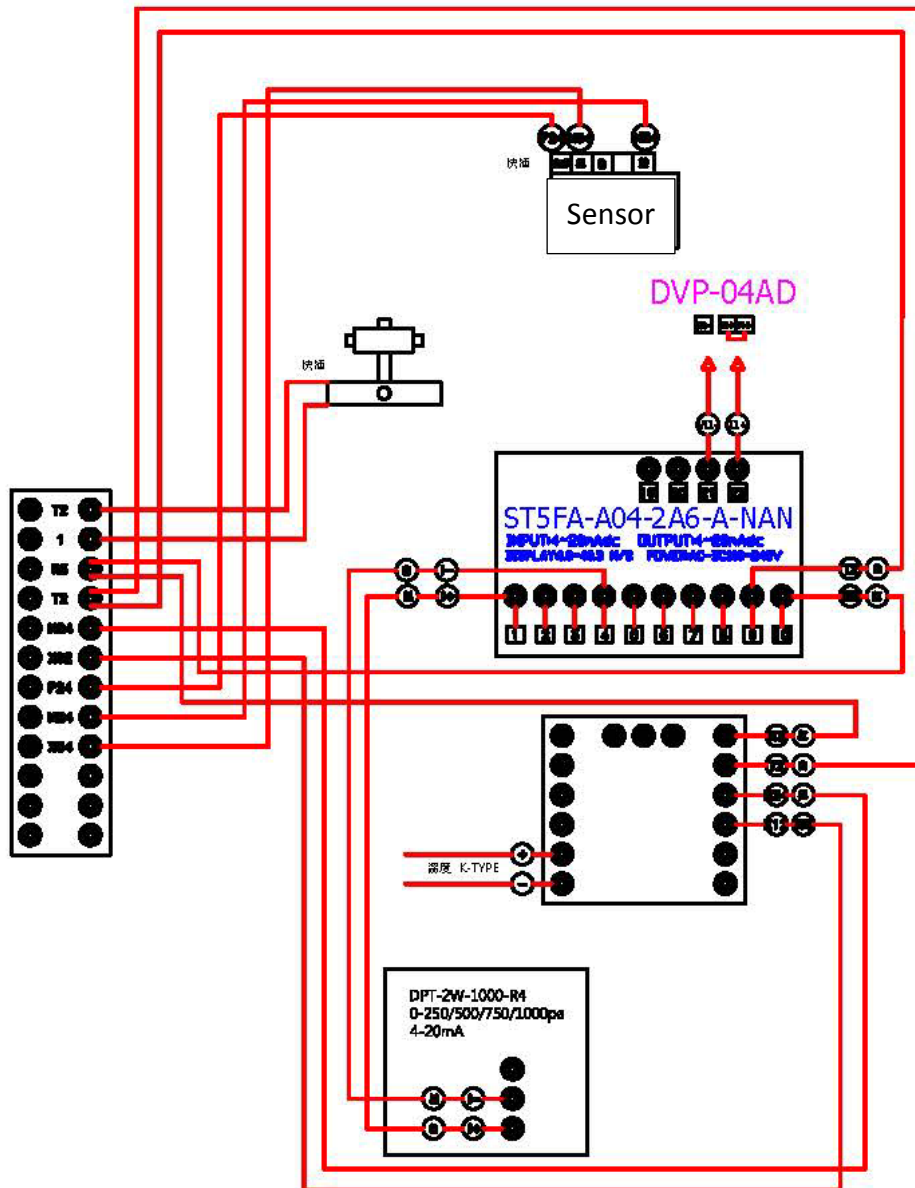

POWER CONNECTIONS



ASSEMBLY INSTRUCTIONS:



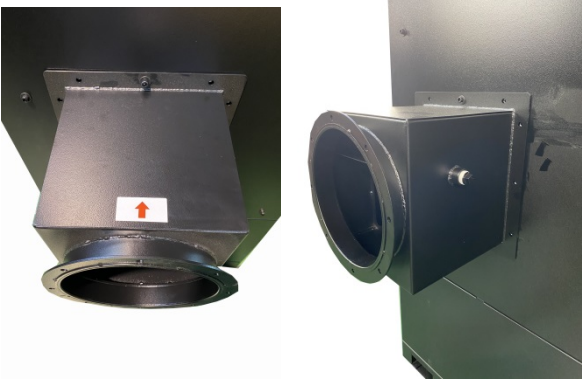
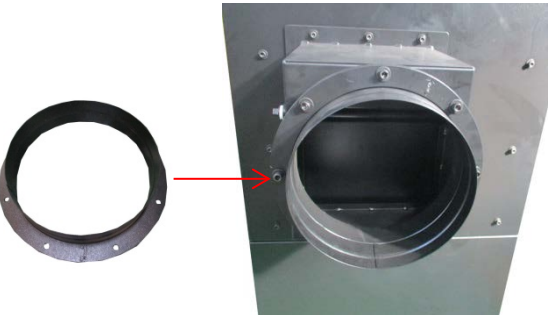

Inlet adapter

You need to install the inlet adapter to this machine. This machine is designed where you can install the inlet adapter either on the left side or right side of the machine, depending on your setup.

	<ol style="list-style-type: none">1. Before attaching the inlet adapter, you will need to seal the inlet opening.2. Apply 3 x 19mm foam tape to four inner edges within the bolts holes.
	<ol style="list-style-type: none">3. Apply 3 x 6mm foam tape on top of the 3x19mm foam tape as shown above.
	<ol style="list-style-type: none">4. Use (12) 3/8" x 3/4" Sunken hex bolts and (12) 3/8" x OD23 x 2t flat washers to secure the inlet adapter to the opening. Make sure the Red arrow faces up in order for the shutter in the intake to work properly.
	<ol style="list-style-type: none">5. Use (8) 3/8" x 1" Sunken hex bolts, (16) 3/8" x OD23 x 2t flat washers and (8) 3/8" hex nuts to attach the flange to the inlet adapter.

Pressure Regulating Valve

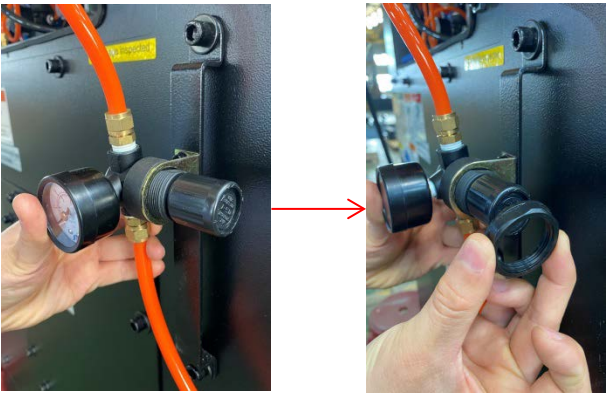
You need to attach the pressure regulating valve to the support bracket, located below the control panel on the dust collector.

 <p>Plastic fastener</p>	<ol style="list-style-type: none"> 1. Remove the securing plate from the pressure regulating valve by loosening the plastic fastener of the pressure valve. Set the fastener aside for step 3.
	<ol style="list-style-type: none"> 2. Use (2) M5 x 10mm Sunken hex bolts and (2) 3/16" x OD13 x 1t flat washers to attach the securing plate to the support bracket.
	<ol style="list-style-type: none"> 3. Take the pressure regulating valve and insert the regulator through the securing plate. Take the plastic fastener and tighten the regulator with the securing plate.
	<ol style="list-style-type: none"> 4. Adjust the pressure regulating valve so that the gauge is within visible location for monitoring the pressure parameters.

TOUCHSCREEN CONTROL

1. Touch the screen to unlock and to show the manual and auto mode screen as below:

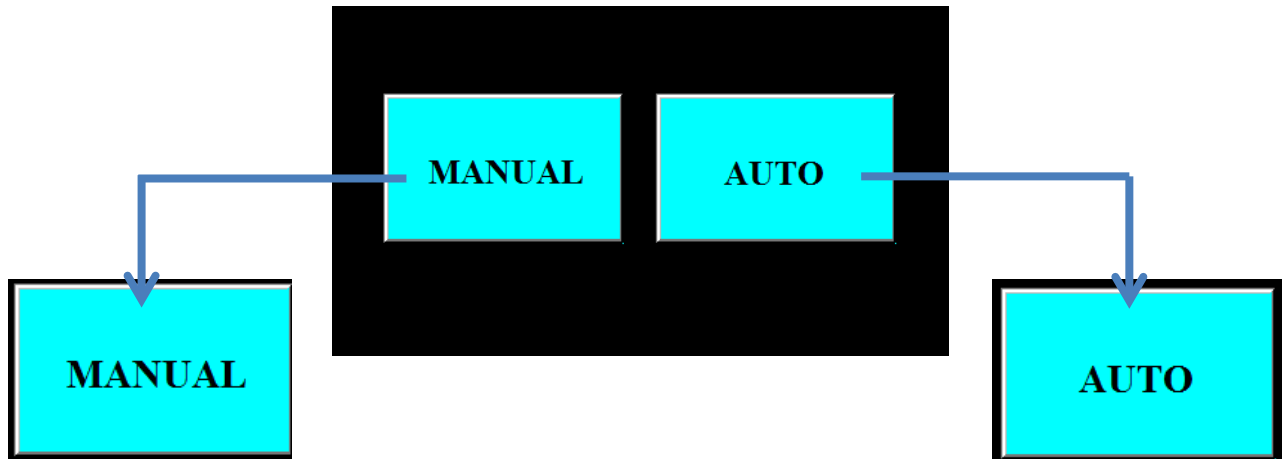

★ Press the operation mode you need for 2 seconds; this will turn the operation mode chosen into a green color. See below.

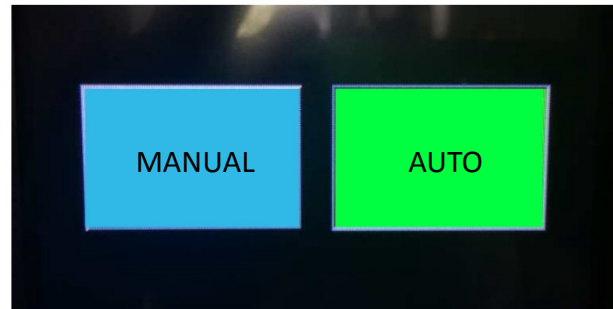
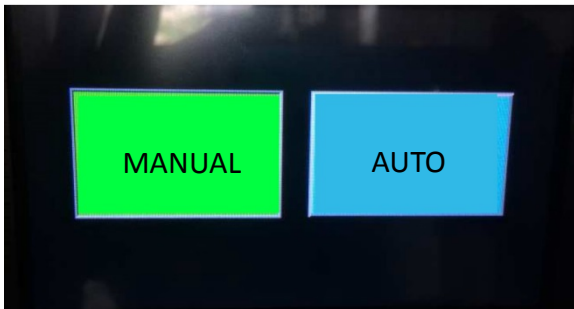
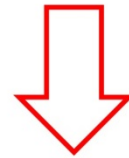
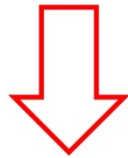

- ※ **MANUAL MODE:** Manually switch ON and OFF unit by pressing this button. This setting will not allow this dust collector to operate in connection with your laser cutting machine. When a red warning appears on this dust collector, there will not be a signal sent to the laser cutting machine to stop operating which may cause dangerous hazards.
- ※ **AUTO MODE:** This setting will link this dust collector to your laser cutting machine.

2. Operation mode screen display

2.1. AUTO MODE

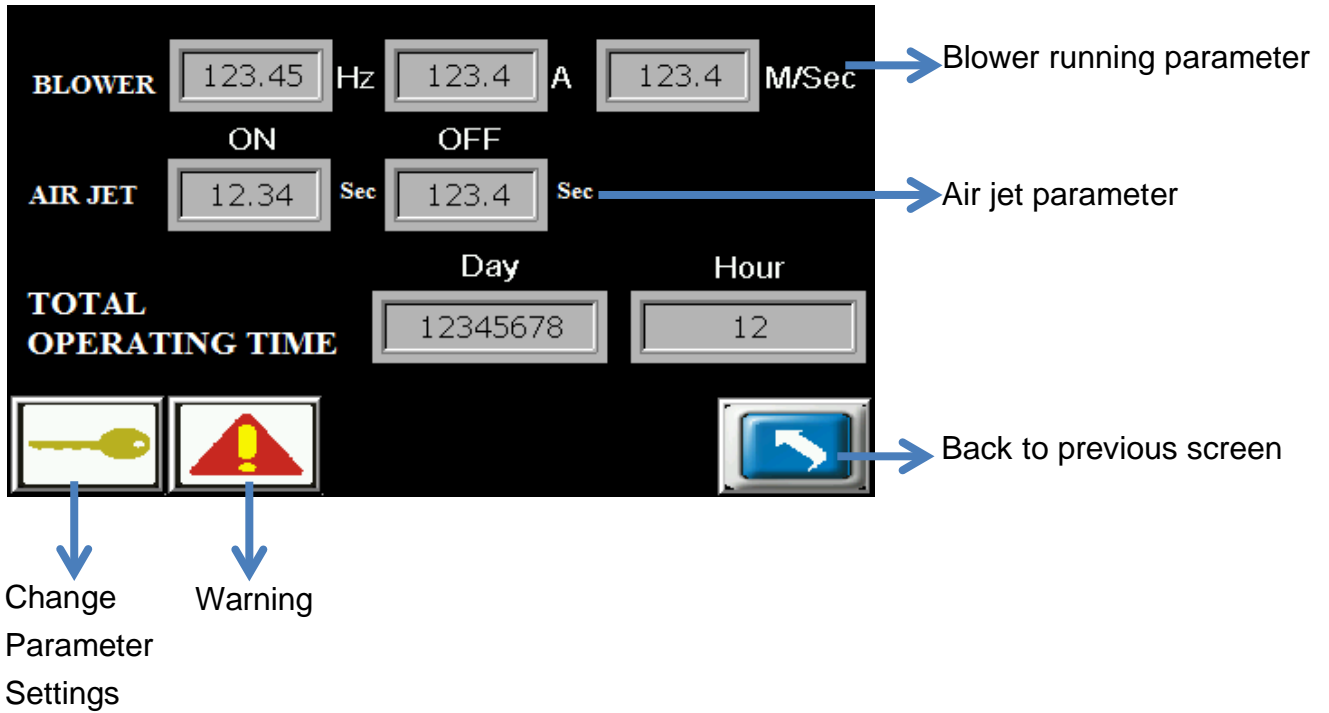

2.2. MANUAL MODE

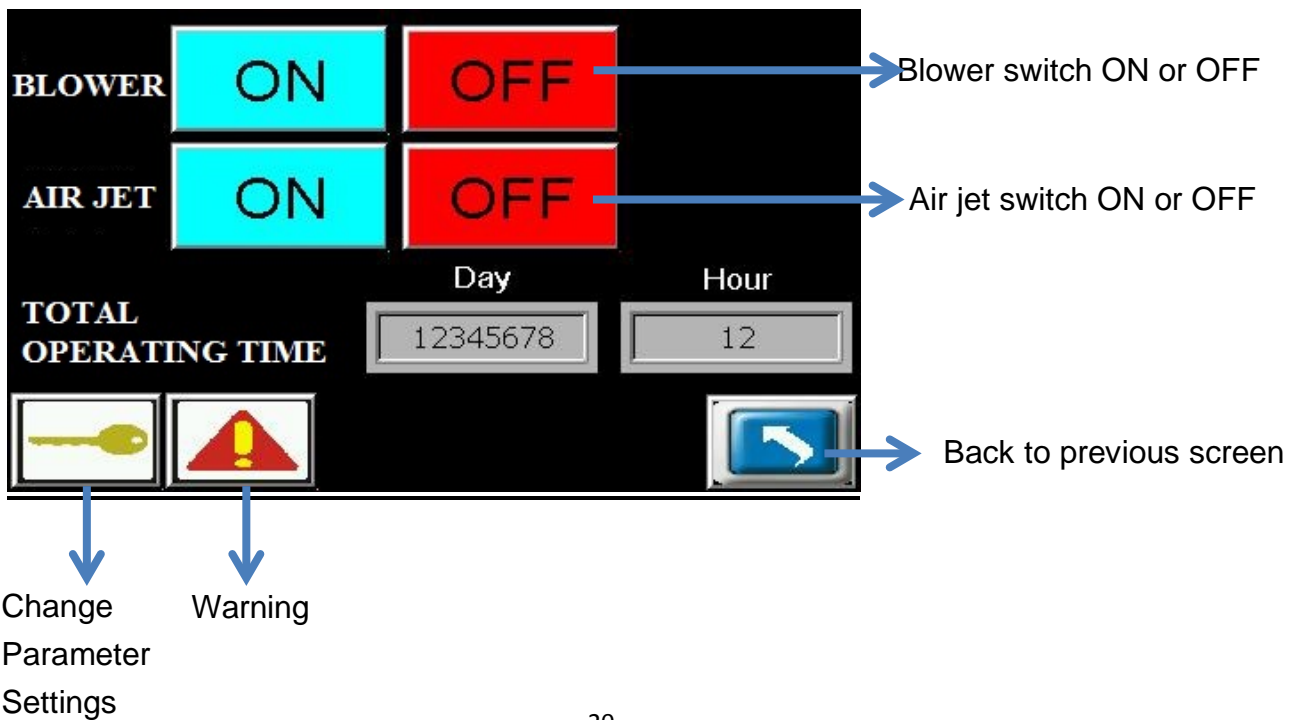

2.3. MANUAL MODE – BLOWER:



Press ON for 2 seconds to turn the blower (unit) ON.



The ON button will turn green during operation.



Press Off for 2 seconds to turn the blower (unit) OFF.

2.4. MANUAL MODE – AIR JET:



Press ON for 2 seconds to turn the air jet to clean filters ON.



The ON button will turn green during operation.



Press Off for 2 seconds to turn the air jet to clean filters OFF.

3. Screen display explanation

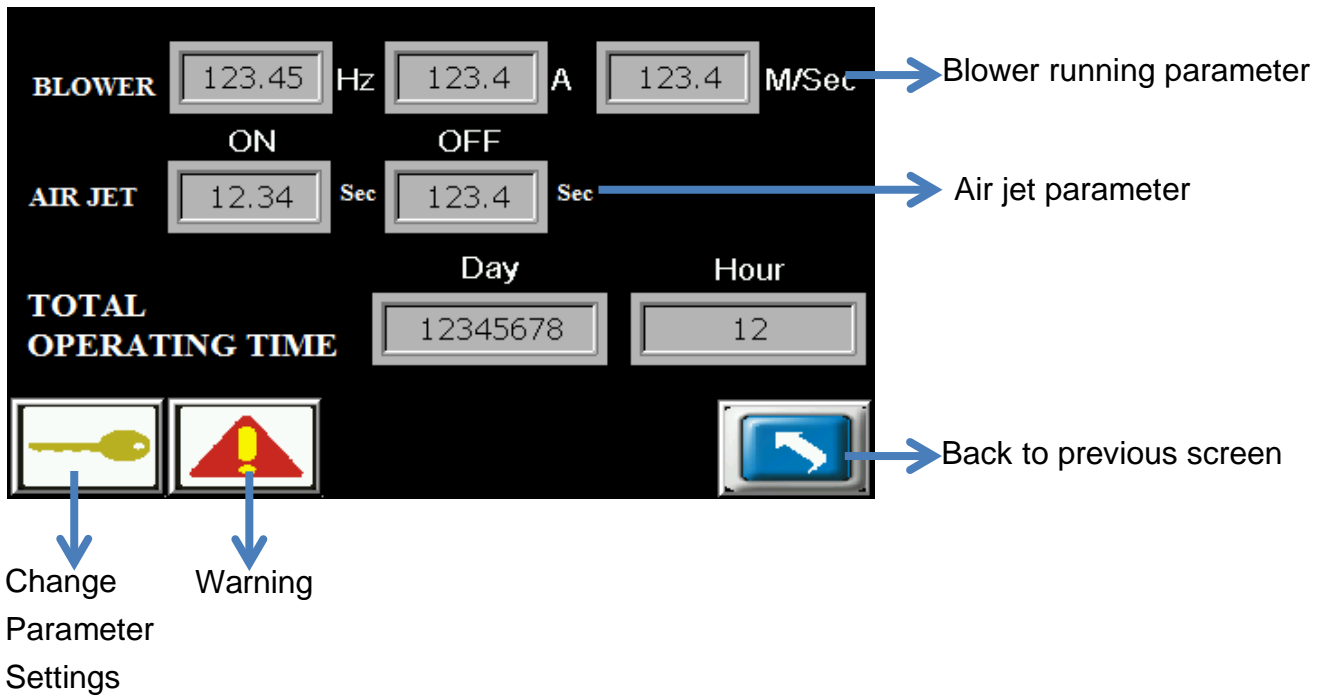

Warning: record malfunction reasons and time.



Records unit total operating time



Change Parameter Settings: you will be able to change the parameter settings here to the desired settings per your environment.

4. WARNING ALERT

FIRE ALERT

When the temperature inside the collector is too high [exceeding 50° C (122

Fahrenheit)] , the warnings **FIRE ALERT**、**INSUFFICIENT**

NITROGEN、**COLLECTOR**

OVERLOAD continuously flash. The collector will stop.

When the malfunction has been fixed, press the



and enter the password (0000) (4 zeros) to restart the collector.



**INSUFFICIENT
NITROGEN**



**COLLECTOR
OVERLOAD**

※When the temperature inside the collector is too high or under fire, the fire suppressing nitrogen will activate.

※When in manual mode, the dust collector cannot switch off the laser cutting machine.

※When the red warnings light up; please contact the manufacturer.

4.1. YELLOW WARNING ALERT

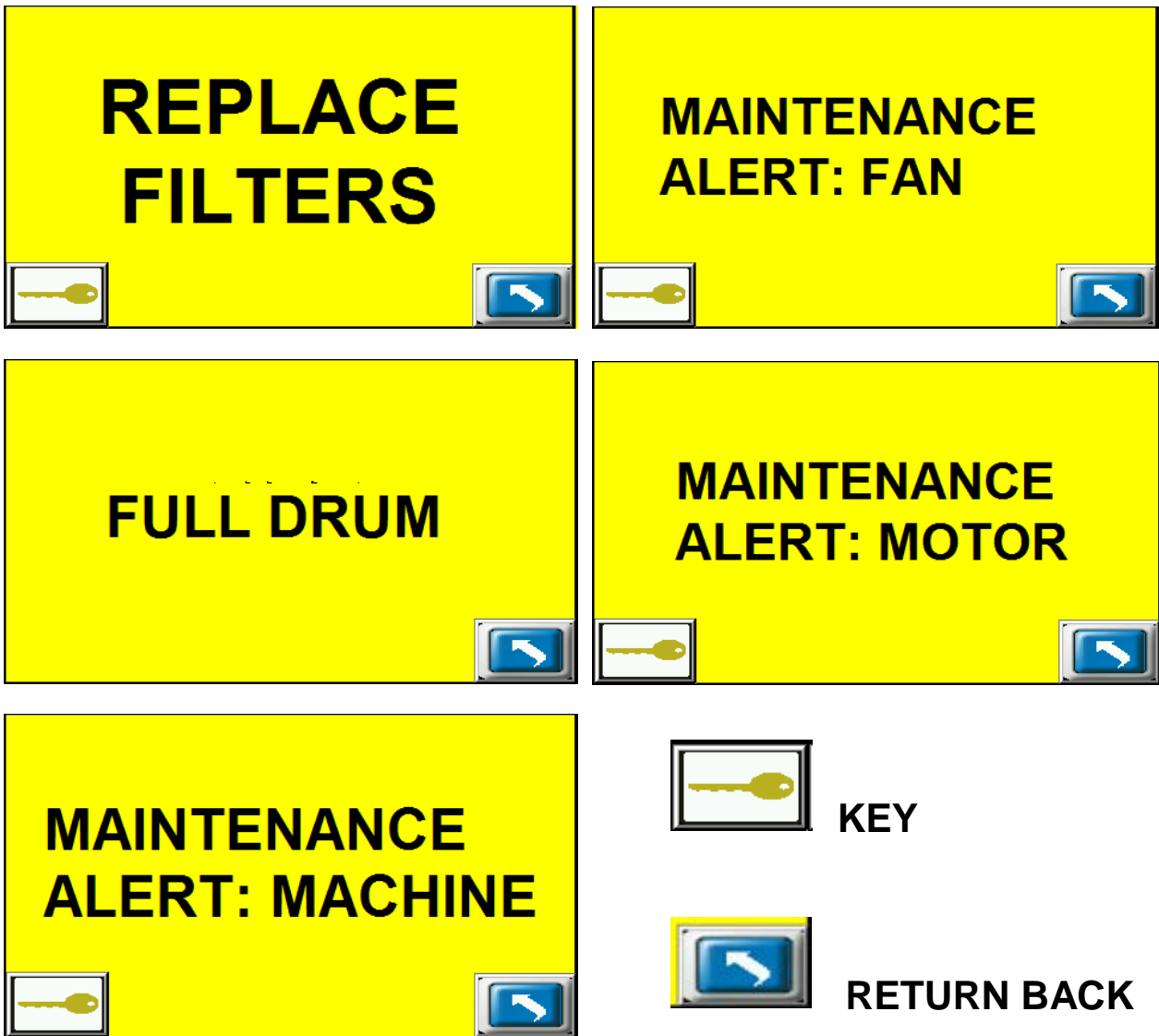

Yellow warning alert means that the consumables need maintenance. If the REPLACE FILTERS 、 FULL DRUM 、 FAN MAINTENANCE 、 MACHINE MAINTENANCE 、 MOTOR MAINTENANCE , please contact the manufacturer for servicing or parts replacement.

4.2 TOUCHSCREEN CALIBRATION

If the touchscreen displays **Delta HMI Touch Calibration**, touch the calibration target firmly and precisely with your fingertip. *During calibration, be careful to keep your fingernails and other fingers away from the touchscreen as you touch each target.* Repeat the procedure for each target as they appear.

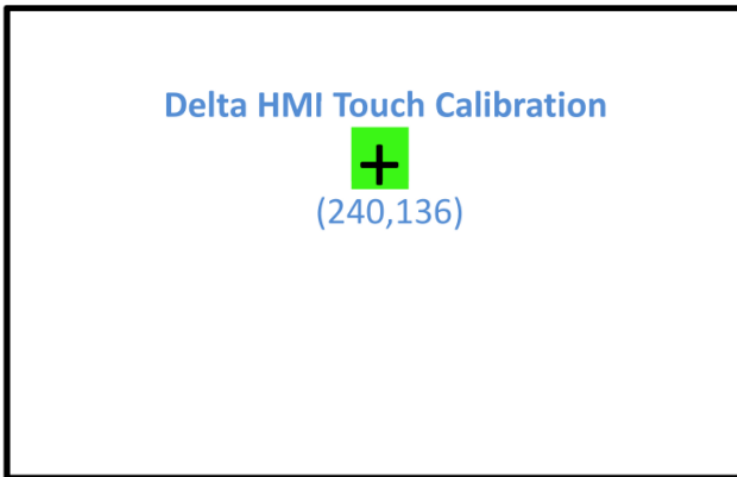

After **five** targets have appeared and calibrated the touchscreen will display **Delta HMI Touch Point Check**. Another target will appear. Touch the calibration target firmly and precisely with your fingertip. After three targets have appeared, return back to the main screen to complete the setting.

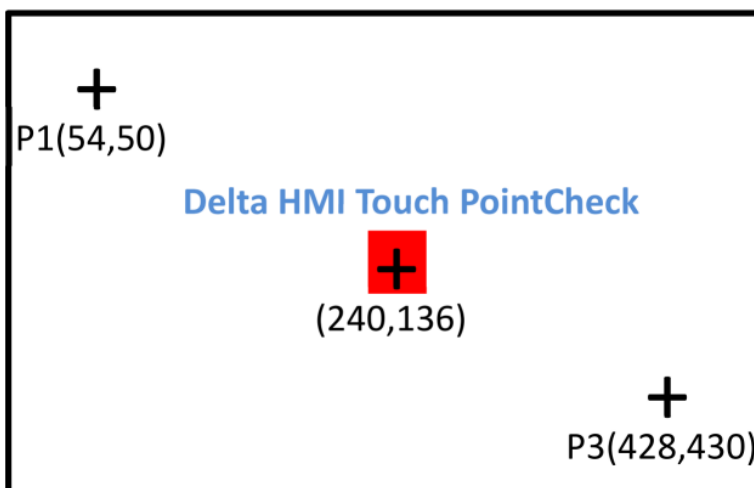

When the collector has reached the pre-set operating time, this means that the consumables will need to be cleaned or replaced to ensure efficiency and safe use.

If the yellow warning continues to flash; please contact the manufacturer to service your machine to prevent any hazards.

★ **Recommended maintenance/service hours:**

5000 hours of use - replace filters, machine maintenance

8000 hours of use – motor maintenance, fan maintenance

✘ **When the yellow warnings flash, the collector will still operate; there will be detection and warning alert every 30 minutes until the warning has been cleared. When the warning has been cleared, press the**

key  , and enter the password (0000) (4 zeros) to clear the warning.

5. Alarm List :

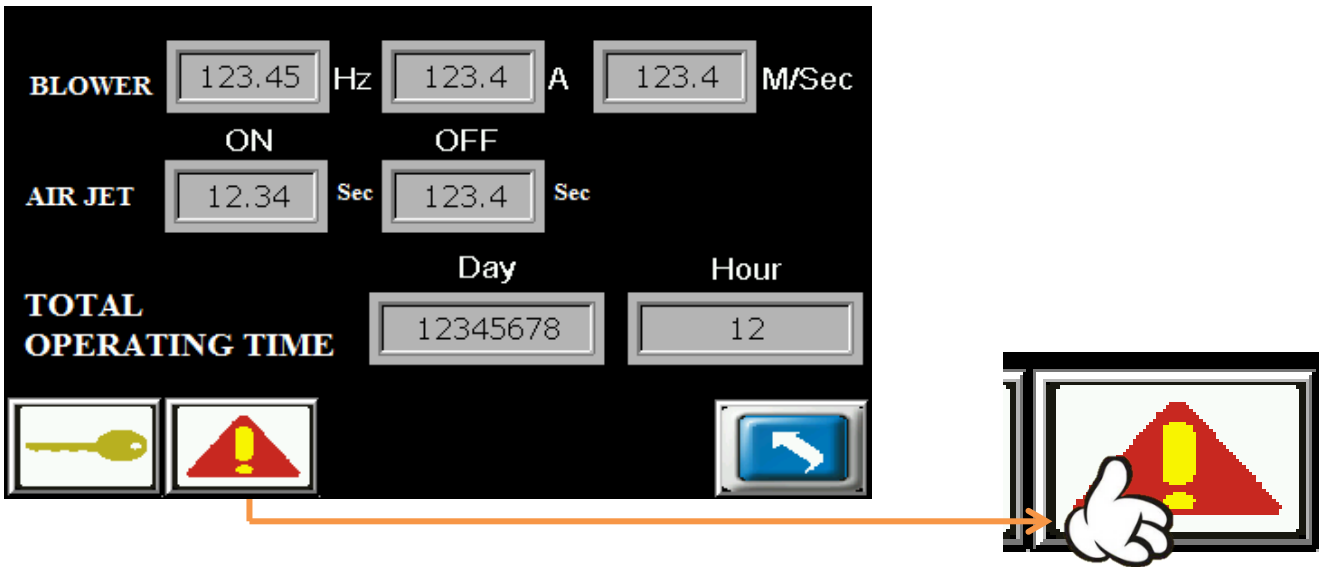

Warning List

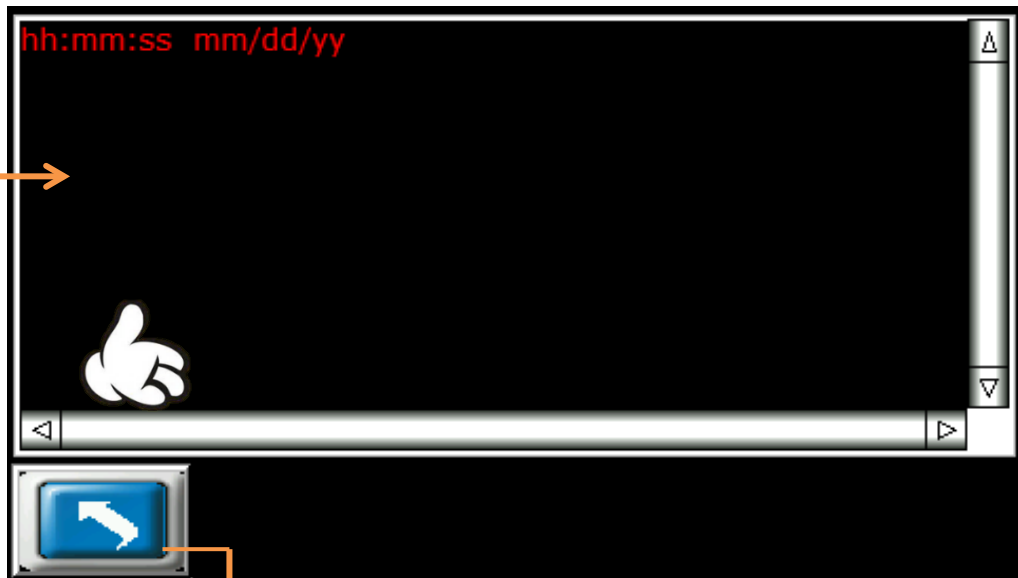

Figure 9

RETURN BACK

Touching the screen will show the date the warning was detected.

6. **Change parameter setting :**

During operation mode, press the “change parameter setting” option on the screen.

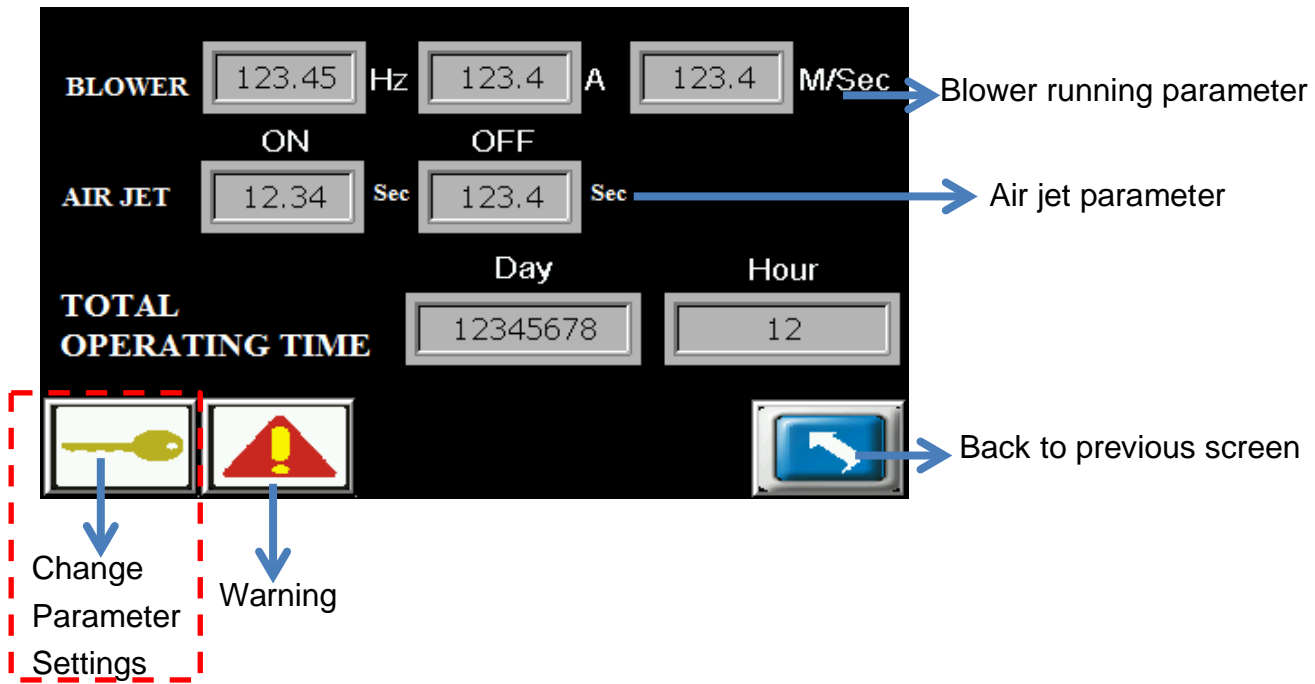

Enter the pre-set password 0000 (4 zeros); then press Enter

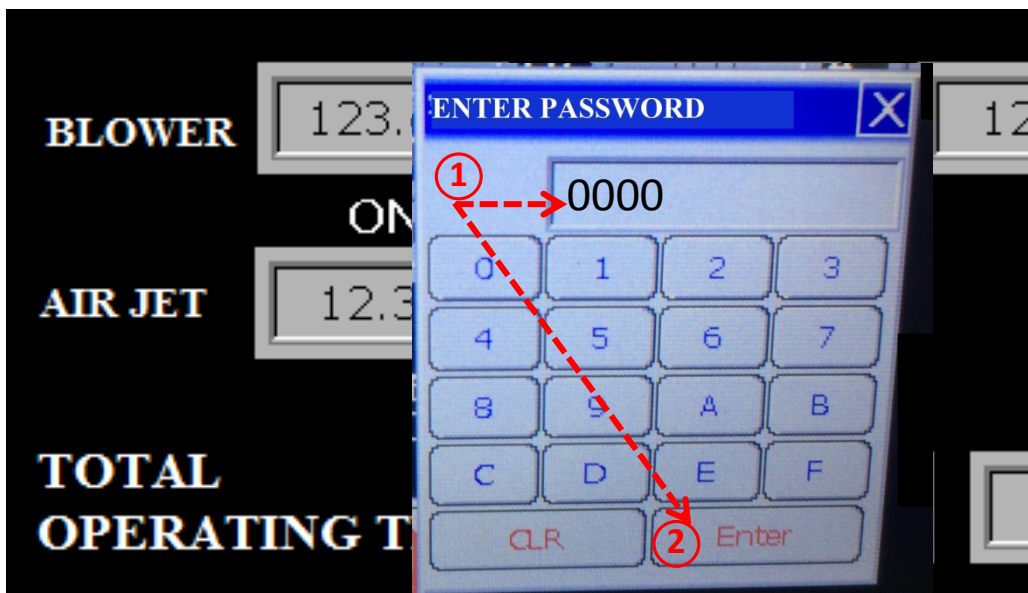

EFLUX7 Laser Cutting Dust Collector

Once you have entered the password, you will be able to change the parameter settings of this dust collector. However it is advised not to change the settings pre-set by the manufacturer for the most suitable operation conditions for this unit.

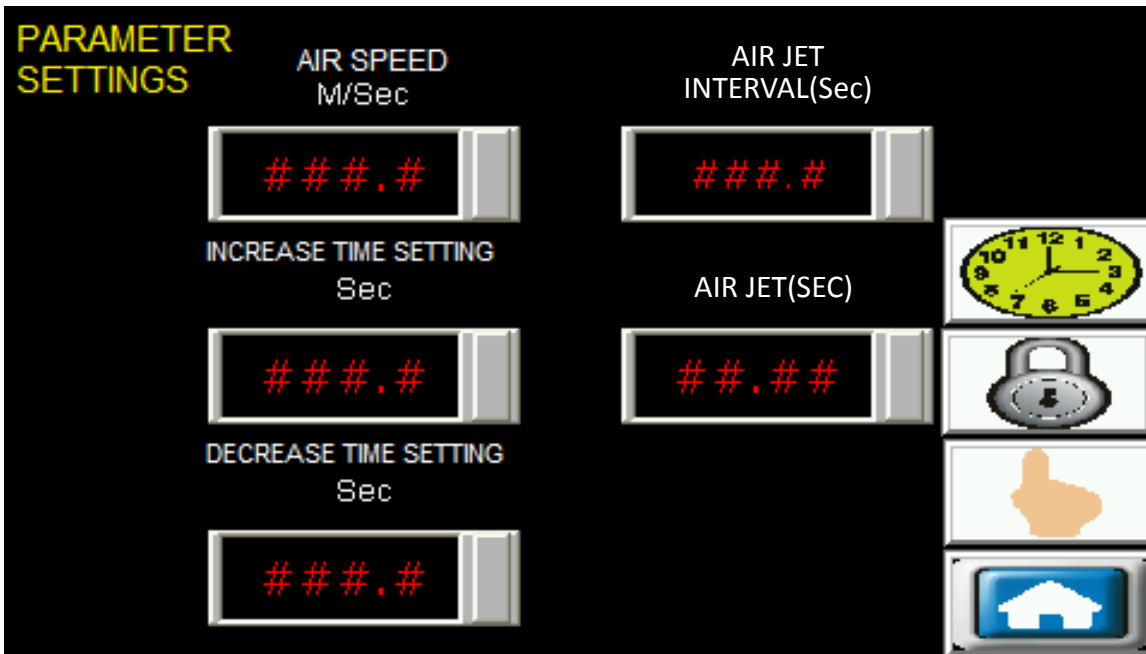

!! DO NOT CHANGE PARAMETERS YOURSELF!!

7. Emergency stop :

Push the emergency stop button when there is a critical situation to stop this dust collector and your laser cutting machine.



☆ When your setting is in manual mode, pressing this emergency stop button will not stop your laser cutting machine simultaneously.

■ **Machine start up and stop (Auto / Manual)**



ATTENTION :

- ※ Install a power circuit breaker to ensure maximum safety.
- ※ Read the manual warnings carefully.
- ※ Carry out the before operation inspection procedure.
- ※ When this unit is abnormal do not start up or operate the unit.

(Refer to troubleshooting P.41~P.42) ◦

1. Before start up inspect the following:

- 1.1 Check the correct power and voltage is connected.
- 1.2 Check that the unit is grounded correctly.
- 1.3 Check that the components are correctly assembled.
- 1.4 Check that there are no abnormal objects inside the collection drums.
- 1.5 Check that the 4kg/cm² compressed air connection to the unit is connected properly.
- 1.6 Check that the 8kg/cm² nitrogen (N₂) connection to the unit is connected properly.

※Nitrogen (N₂) is used as a fire suppression, do not use any other gases as this will cause major damage and serious injuries.

2. Starting up and stopping :

- 2.1 Switch on your main power source.
- 2.2 Press (touch) the ON switch on the screen to start up the unit.
Press (touch) the OFF switch on the screen to stop the unit.

※Check the fan/impeller rotation direction and the motor fan rotation direction are in the same direction as the rotation sticker/label

2.3 Air jet cleaning and machine setup

Air jet settings can be entered into by going to the change parameter settings option; if you want to change the parameters.

- ※Pulse interval time—10sec
- ※Pulse jet cleaning time — 0.08sec
- ※Air speed setting — 6 m/sec
- ※Startup: increase time setting —25sec
- ※Stop/Off: decrease time setting —25sec



2.4 Switch ON the unit

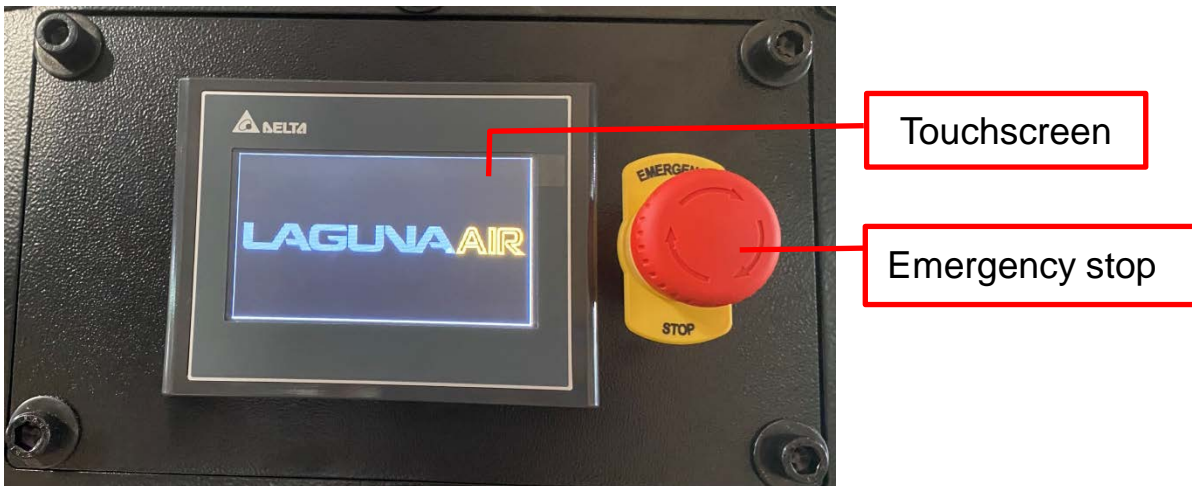

2.5 Screen display: Startup and stop

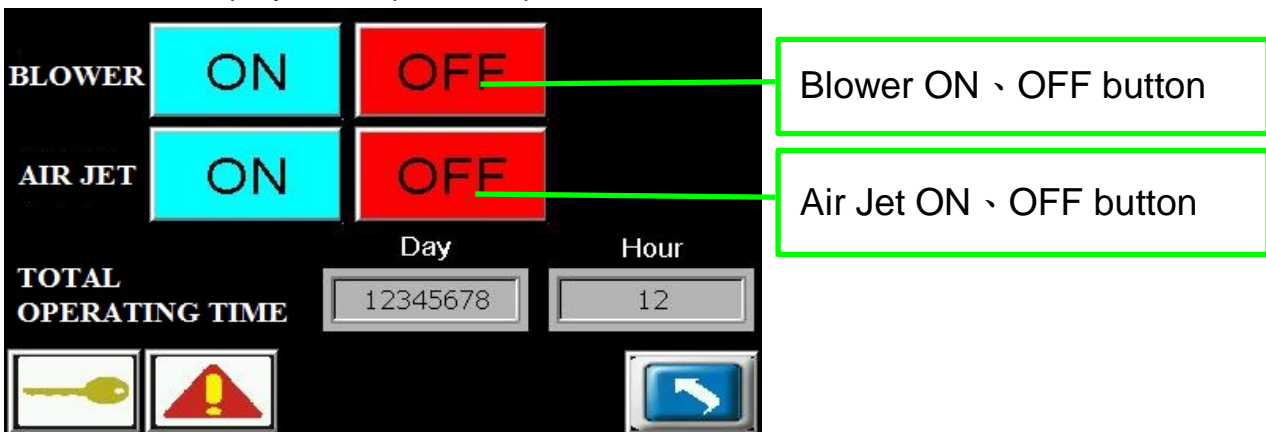

2.6 When the touchscreen shows a red alert, the blower and air jet will stop running.

2.7 If the user discovers the fire before the unit signals the fire alert; press the emergency stop button immediately to stop the unit.

(Extinguish the fire immediately, using your fire extinguisher)

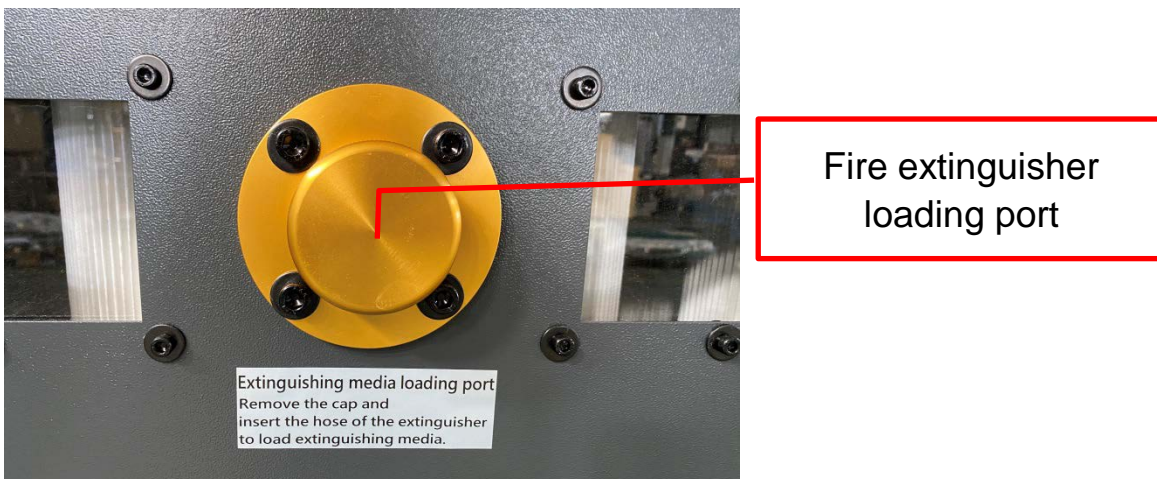
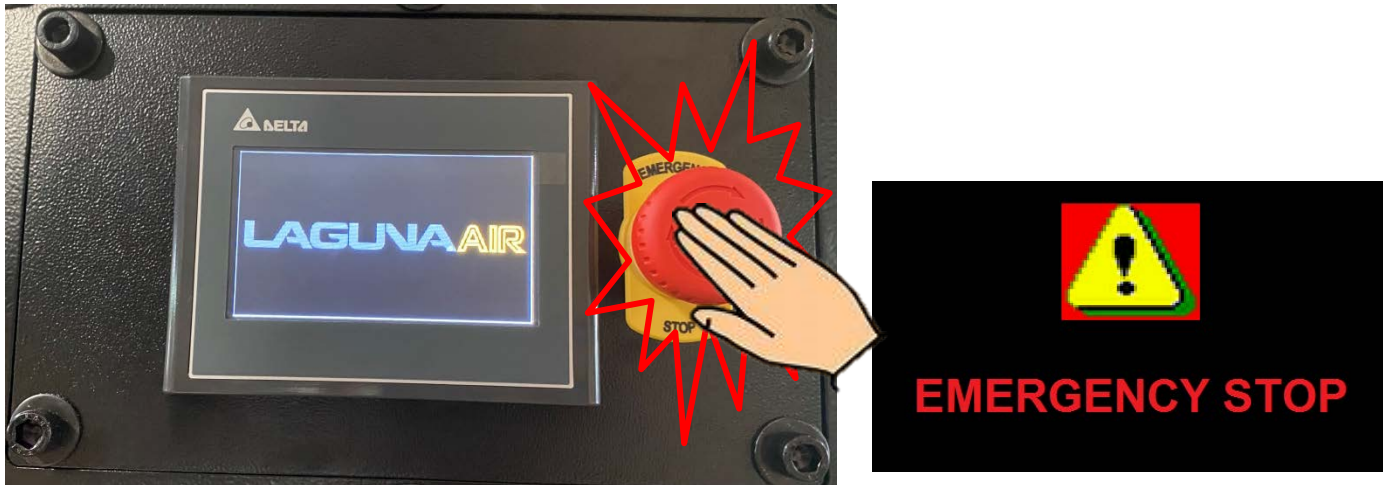

CAUTION!

Nitrogen pressure at 8kg/cm² is a fire suppressant to prevent the fire from spreading. It is not the source of extinguishing the fire.

Fire suppression. Only operate the dust collector in locations that contain a fire suppression system or have a fire extinguisher nearby.

■ **Canister filter maintenance and replacement :**



WARNING : Regularly checks if the canister filters need to be replaced to prevent fire hazards

※When the total operating time reaches 5000 hours, follow the procedures below to replace your filters. Inspect and maintain the filters; if you find them to be damaged, replace immediately.



WARNING : Before replacing or maintaining the filters, make sure you switch the unit OFF and remove power source. Wear a mask and goggles when replacing or maintaining the filters. Follow the replacement steps below for replacing the filters. There may be the hazard of dust entering nose, mouth and eyes. Make sure you are protected beforehand.

1. Open the maintenance door. (Figure 1) ◦

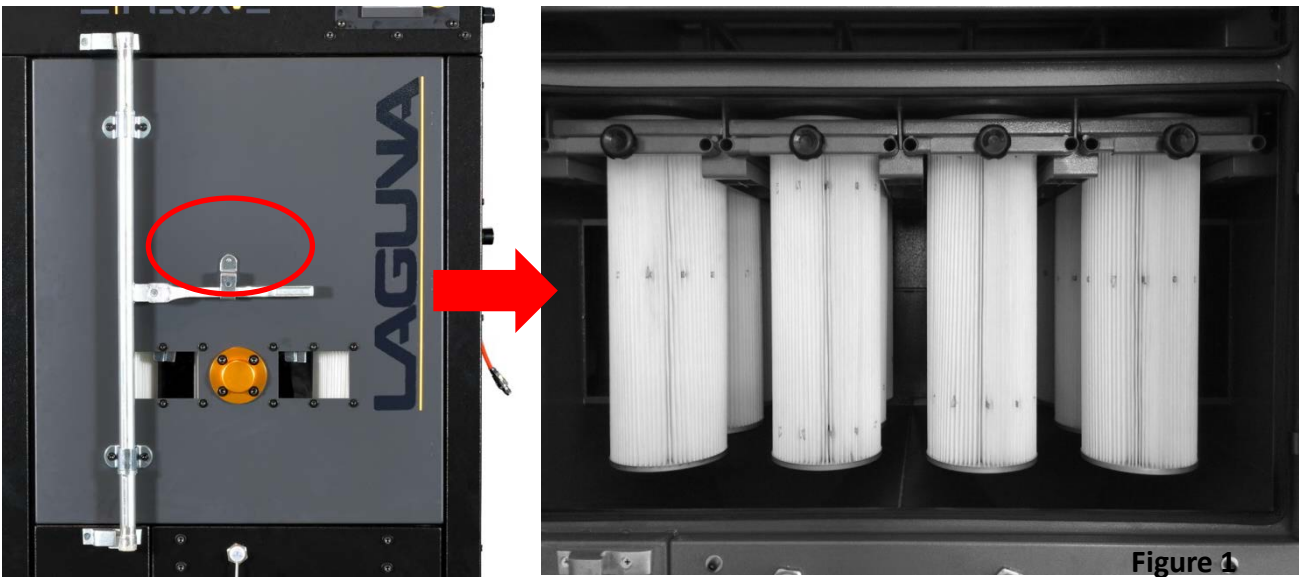

2. Loosen the knob shown below (Figure 2) , and lower the levers (Figure 3) ◦

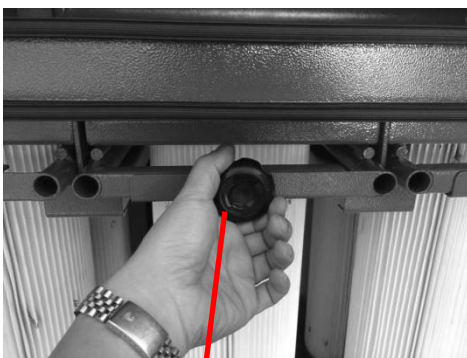

Knob

Figure 2

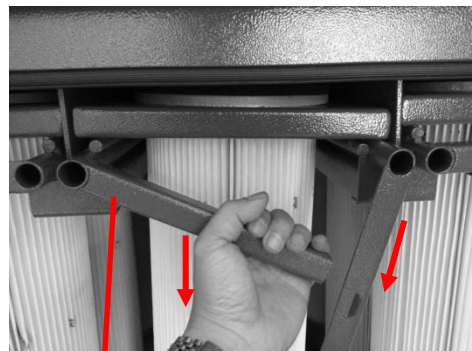

Lever

Figure 3

EFLUX7 Laser Cutting Dust Collector

3. Carefully slide out the filters by pulling out the plate (Figure 4) ·
Set the filters on the floor and carefully slide down the plate to remove the old filters (Figure 5) · insert the new filters onto the plate.(Figure 6) ·



Figure 4



Figure 5



Figure 6

4. After inserting the new filters on the plate, carefully slide the plate upwards (Figure 7) · and tighten the knob to secure the levers in place. (Figure 8) ·

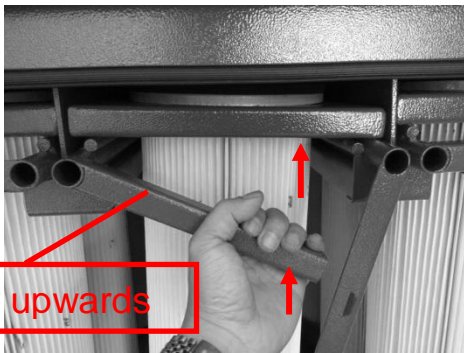

Figure 7



Figure 8

5. Inspect thoroughly that the steps above have been performed correctly; then close the door and lock it tight.



■ Collection drum maintenance and operation



ATTENTION: Clean the collection drum on a daily basis to prevent fire hazard.



ATTENTION: 1. Before cleaning the collection drums, make sure you switch the unit OFF and remove power source.
2. Wear a mask, goggles and gloves.
3. Failure to follow these steps will result in serious injury and dust entering the nose, mouth and eyes.

1. Lift the handle up to release the collection and lower it to the secure plate below.



2. Slide the secure plate out towards you.

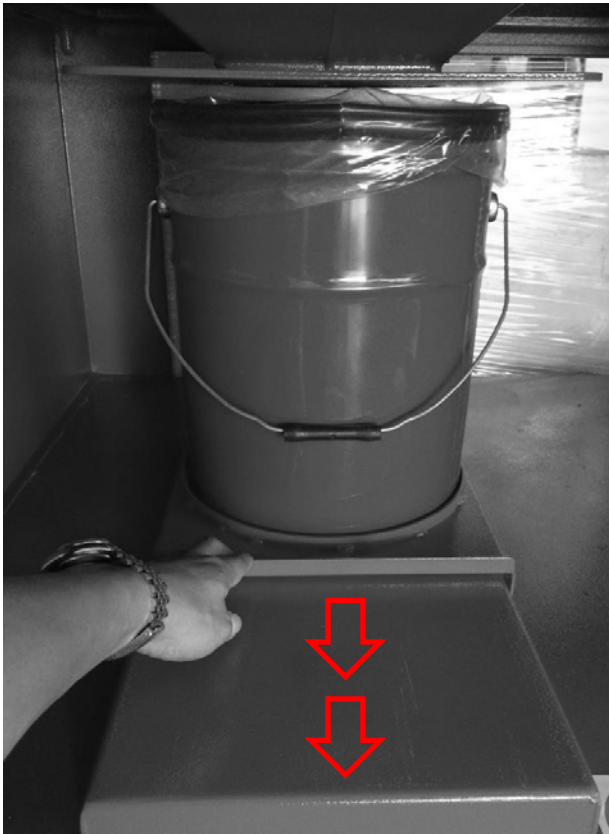

Remove the collection drum and take out the drum insert plate. Remove the plastic bag and replace the plastic bag with a new one.



EFLUX7 Laser Cutting Dust Collector

3. Place the drum insert back into the drum after you have inserted the plastic bag in place. Set the drum on the secure plate.

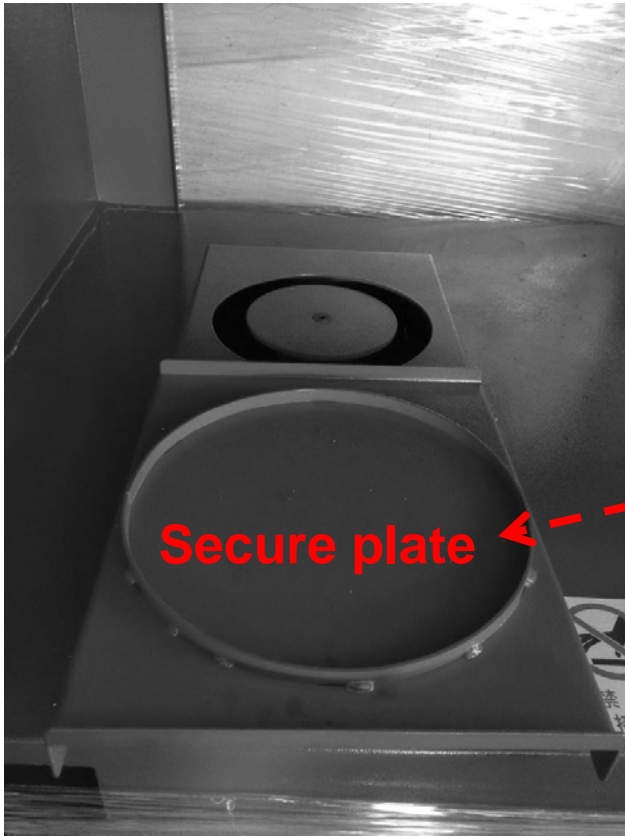

Slide the secure plate with drum on inwards to the very end.

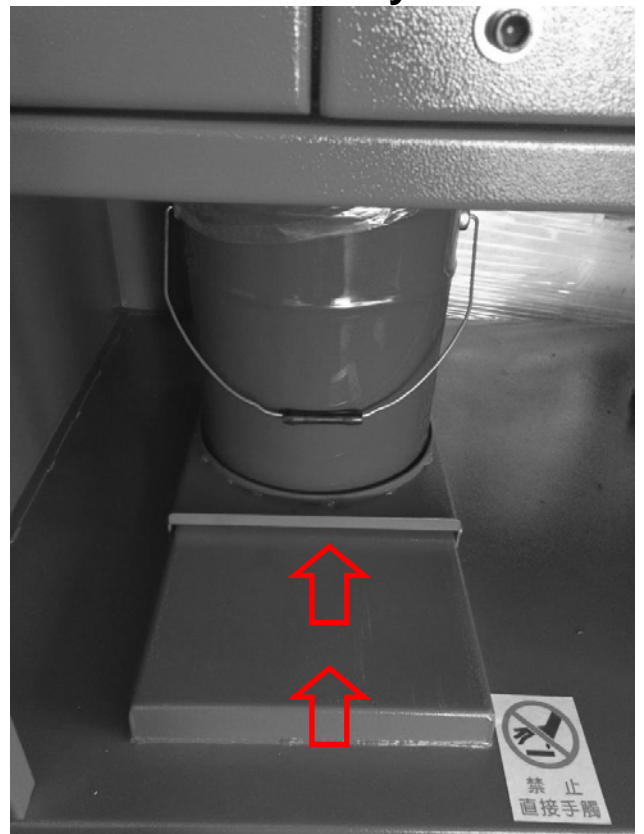

4. Lower the handle up to lift the collection.



The collection drum will move upwards and close up against the top housing for a full seal. **(Do not place your hand on the drum when lifting the drum up towards to the housing; this will cause serious injury.)**



■ Daily inspection

*** Keep and Save these instructions -> (Important information)**

***Do not operate the unit if you find any abnormalities, refer to the troubleshooting or contact the manufacturer immediately**

Before operating the unit, inspect the following:

Component	Inspection time	Item	Method	Standard
Collection drum	Once a day	Is there dust pile up in the drum?	Visual inspection	No dust pile up
Nitrogen(N2) Fire suppression	Once a day	Is the pressure above 8kgf/cm ² ?	Visually inspect the meter/gauge	Above 8kgf/cm ²
Door Window	Once a day	Can you see the inside of the machine from the window?	Visually look through the window	You can see the inside of the machine
Canister filter	Once a week	Is there dust caked up against the inner wall of the filter?	Open the door and inspect the filters	No dust cake
Inlet/intake adapter	Once a month	Is the intake adapter loose or fallen off?	Visual inspection	Tight and attached
		Is it damaged?	Visual inspection	No damage
		Is there dust pile up inside?	Visual inspection	No dust pile up

According to the result of your inspection, if you find an abnormality stop the machine immediately and follow the steps below:

Component	Abnormality found from inspection	Troubleshooting	
Collection drum	Dust pile up	Clean and remove dust pile up	
Nitrogen(N2) Fire suppression	Below 8kgf/cm ²	Replace the Nitrogen (N2) tank	
Door Window	Unable to look through window to inside of unit	clean and wipe the inside of the window	
Canister filter	Canister filter is damaged	Replace filter	
	Secure plate has shifted out of place	Correct and move back in place	
Inlet/intake adapter	Intake adapter loose	Fasten back in place	
	Adapter is damaged	Repair or replace	
	Dust pile up inside	Clean dust pile up	

*1. If Nitrogen (2) pressure is below 8kgf/cm², the unit will stop operating.

When the unit is in operation, inspect the following

Component	Inspection time	Item	Method	Standard
Motor	Once a day	Is there a loud noise or abnormal vibration?	Inspect for abnormal noise or vibration	No loud noise or abnormal vibration
Silencer		Is there dust leaking?	Visually inspect	No dust visible
Dust intake		Normal dust suction no leakage?	Visually inspect	No dust leakage
Dust outlet and collection drum		Has air leaked inside?	Inspect the outlet for any leakage	No dust leakage
		When the air jet pulses is there dust leakage?	Visually inspect	No dust leakage

According to the result of your inspection, if you find an abnormality stop the machine immediately and follow the steps below:

Component	Abnormality found from inspection	Troubleshooting	
Motor	External object obstructing fan/impeller	Clean fan/impeller	Contact manufacturer
	Motor bearing is damaged	Replace motor	Contact manufacturer
Silencer	Filter is worn or foam gasket is worn out/damaged	Replace	Contact manufacturer
	Secure plate has shifted out of place	Correct and move back in place	
Dust intake	Canister filter clogged	Replace filter	Contact manufacturer
	Air jet malfunction/damaged	Repair or replace	
	Dust clog inside dust intake adapter	Remove dust clog	
Dust outlet and collection drum	Air leaked inside	Replace gasket and foam tape	Contact manufacturer
	Dust leaking out		

*Daily inspection can prevent any abnormalities.

*If any abnormalities are found and detected, stop operating the machine. As this may affect other linked systems function and operation.

*Consumables need to be replaced at the recommended or frequent basis to maintain the most efficient performance of your machine.

Troubleshooting



If there are abnormalities during operation, stop the machine immediately

Yellow alert appears on the touchscreen

Problem found	Reason	Troubleshooting method
REPLACE FILTERS	Machine total operating hours has reached 5000 hours	Replace filter and reset the operating hours
MACHINE MAINTENANCE	Machine total operating hours has reached 5000 hours	Inspect machine components and service parts
MOTOR MAINTENANCE	Machine total operating hours has reached 8000 hours	Inspect and service motor or replace motor
FAN MAINTENANCE	Machine total operating hours has reached 8000 hours	Inspect and maintain fan/impeller or replace fan/impeller.

Red alert appears on the touchscreen

FIRE ALERT	Temperature detection abnormal	Replace temperature detection Check if the temperature detection wire has snapped
	Fire hazard inside of machine	Extinguish fire
INSUFFICIENT NITROGEN	Not enough Nitrogen(N2)	Replace the Nitrogen tank
		Reset the screen to remove the alert signal
COLLECTOR OVERLOAD	Damaged motor, abnormal fan/impeller, abnormal inverter setting	Switch off the unit and contact the manufacturer

Problem found	Reason	Troubleshooting method
Dark screen – nothing showing (touchscreen)	O Is the power source OFF	O Switch ON the power source
	O Loose cord or cutoff	O Tighten cord or replace cord
Dust found on outlet	O Filter gasket damaged	O Replace filter
	O Filter material damaged	O Replace filter
	O Displacement of filters °	O Relocate filter in correct position
Dust leaking from maintenance door.	O Gasket not making a full seal	O Replace gasket
	O Damaged gasket	O Replace gasket
	O Door or hinges damaged	O Repair or replace door or hinges
Abnormal sound or too much vibration.	O External object obstructing fan	O Clean fan
	O Motor bearing damaged	O Replace bearing
	O Fan bolt loosened	O Tighten bolt
When the machine is ON; never move the unit or replace or service any components	O Faulty motor	O Repair or replace
	O Faulty power cord	O Replace
	O Relay on the motor has tripped	O Switch off the power source and contact manufacturer
	O Nitrogen N2 below 8kgf/cm ² °	O Replace Nitrogen tank
When the power source is ON; but the overload trips.	O Power cord short circuit	O Inspect correct connection
	O Short circuit	O Contact manufacturer
Sudden stop (unit)	O Motor overload	O Contact manufacturer
Compressed air leakage (Air jet internal ducting)	O Air jet magnetic valve diaphragm damaged	O Replace diaphragm and spring
	O Foreign object clogging magnetic valve.	O Clear out
	O Connectors or duct leaking	O Replace connectors
Dust intake pressure drop	O Air jet system causing error	O Adjust air jet interval time
		O Adjust air jet pulse pressure
	O Humidity	O Get rid of cause of humidity
	O No daily emptying of drum	O Empty the drum
	O Clog	O Replace filter or magnetic valve
	O Dust build up at intake pipe	O Clean the intake pipe
Irregular air flow	Wires in control box loose	Contact manufacturer
	Pressure tubes PT or PS loose	Clear the clog and reconnect tubes
Blower cannot startup or irregular operation	Blower cannot startup, inverter signal is abnormal	Check the wire connection
	Wires in control box loose	Switch off the unit and contact the manufacturer
	Touchscreen cannot deliver signal	

* When replacing the parts like filters, there will be dust that comes out from the outlet.

NOTES

LAGUNA

LAGUNA AMERICAN HEADQUARTERS

Texas: 744 Refuge Way Suite 200, Grand Prairie, Texas 75050, U.S.A. Phone: +1-800-332-4094

Huntington Beach: 7291 Heil Ave Huntington Beach, CA 92647, U.S.A. Phone: +1-949-474-1200

South Carolina: 825 Bistline Dr. Ste 101, West Columbia, SC 29172, U.S.A. Phone: +1-800-234-1976

Minnesota: 5250 West 74th St, Edina, MN 55439, U.S.A Phone: +1-949-474-1200

DAKE CORPORATION

724 Robbins Road, Grand Haven, MI 49417, United States +1-800-937-3253

LAGUNA EUROPE

Walker Rd, Bardon Hill, Coalville LE67 1TU, United Kingdom. Phone: +44-1530-516921

© 2020 Laguna Tools