

iFLUX: 10

Owner's Manual



10HPBAG FILTER DUST COLLECTOR

LAGUNA



Thank you for investing in a Laguna Tools iFLUX10 dust collector. These dust collectors are a part of a family of unique machines proudly offered by Laguna Tools. Every Laguna machine is engineered for years of dependable service. Please feel free to contact Laguna Tools if you have a question or suggestion. We appreciate working with you and your choice of a Laguna Tools machine for your shop.

Regards,
Torben Helshoj
President & Founder Laguna Tools

This manual applies to the iFLUX10 dust collector. Enter the model number and serial number below for quick reference when ordering accessories, supplies or parts.

Model: _____

Date of purchase: _____

Serial: _____

Place of purchase: _____

LATEST MANUAL:

Below is a QR code which will direct you to the industrial machine reference page, your machine and the latest version of the manual is located on the Laguna Tools website. The online manual may have updates and information added after the printed copy was released. Scan the code with your smartphone or copy the URL link to be directed to the latest manual page to reference your specific machine and model.

<https://lagunatools.com/resources/product-manuals/#industrial>



Laguna Tools 744 Refuge Way, Suite 200
Grand Prairie TX 75050

800-234-1976

www.lagunatools.com



TABLE OF CONTENTS

Important Safety Instructions	4
Safety Guidelines - Definitions	7
General Safety Rules	7
Additional Safety for Dust Collectors	8
Power Connections & Wiring Diagram	10
Motor Specifications	11
Grounding Instructions	11
Control Panel & Remote Control	14
Specifications	15
Assembly	16
Routine Inspection	21
Trouble Shooting	22
Exploded View	24
Parts list	25
Warranty	29



IMPORTANT SAFETY INSTRUCTIONS

⚠ WARNING

READ AND UNDERSTAND ALL WARNINGS AND OPERATING INSTRUCTIONS BEFORE USING THIS EQUIPMENT. Failure to follow all instructions listed below, may result in electric shock, fire, and/or serious personal injury or property damage.

Woodworking can be dangerous if safe and proper operating procedures are not followed. As with all machinery, there are certain hazards involved with the operation of the product. Using the machine with respect and caution will considerably lessen the possibility of personal injury. However, if normal safety precautions are overlooked or ignored, personal injury to the operator may result. Safety equipment such as guards, push sticks, hold-downs, featherboards, goggles, dust masks and hearing protection can reduce your potential for injury. But even the best guard won't make up for poor judgment, carelessness or inattention. **Always use common sense** and exercise caution in the workshop. If a procedure feels dangerous, don't try it. Figure out an alternative procedure that feels safer. **REMEMBER:** Your personal safety is your responsibility.

⚠ WARNING

This machine was designed for certain applications only. We strongly recommend that this machine not be modified and/or used for any application other than that for which it was designed. If you have any questions related to a particular application, DO NOT use the machine until you have first contacted the manufacturer to determine if it can or should be performed on the product.

If you have any questions related to its application DO NOT use the product until you have contacted the manufacturer and we have advised you.

When using an electrical appliance, basic precautions should always be followed, including the following:

READ ALL INSTRUCTIONS BEFORE USING (THIS APPLIANCE)

⚠ WARNING

- To reduce the risk of fire, electric shock, or injury:
1. Do not leave appliance when plugged in. Unplug from outlet when not in use and before servicing.
 2. Do not use outdoors or on wet surfaces
 3. Do not allow to be used as a toy. Close attention is necessary when used by or near children.
 4. Use only as described in this manual. Use only manufacturer's recommended attachments.



5. Do not use with damaged cord or plug. If appliance is not working as it should, has been dropped, damaged, left outdoors, or dropped into water, return it to a service center.
6. Do not pull or carry by cord, use cord as a handle, close a door on cord, or pull cord around sharp edges or corners. Do not run appliance over cord. Keep cord away from heated surfaces.
7. Do not unplug by pulling on cord. To unplug, grasp the plug, not the cord.
8. Do not handle plug or appliance with wet hands.
9. Do not put any object into openings. Do not use with any opening blocked; keep free of dust, lint, hair, and anything that may reduce air flow.
10. Keep hair, loose clothing, fingers, and all parts of body away from openings and moving parts.
11. Turn off all controls before unplugging.
12. Use extra care when cleaning on stairs.
13. Do not use to pick up flammable or combustible liquids, such as gasoline, or use in areas where they may be present.
14. Connect to a properly grounded outlet only. See Grounding Instructions.

SAVE THESE INSTRUCTIONS

1. Read and understand the warnings posted on the machine and in this manual. Failure to comply with all of these warnings may cause serious injury.
2. Replace the warning labels if they become obscured or removed.
3. This Dust Collector is designed and intended for use by properly trained and experienced personnel only. If you are not familiar with the proper and safe operation of this type of dust collector, do not use until proper training and knowledge have been obtained.
4. Do not use this machine for other than its intended use. If used for other purposes, **LAGUNA TOOLS INC.**, disclaims any real or implied warranty and holds itself harmless from any injury that may result from that use.
5. Always wear approved safety glasses/face shields while using this machine.
6. Before operating this dust collector, remove tie, rings, watches and other jewelry, and roll sleeves up past the elbows. Remove all loose clothing and confine long hair. Non-slip footwear or anti-skid floor strips are recommended. Do **not** wear gloves.
7. Wear ear protectors (plugs or muffs) during extended periods of operation.

Proposition 65 Warning

8. Some dust created by power sanding, sawing, grinding, drilling and other construction activities contain chemicals known to cause cancer, birth defects or other reproductive harm. Some examples of these chemicals are:
 - Lead from lead-based paint.
 - Crystalline silica from bricks, cement and other masonry products.
 - Arsenic and chromium from chemically treated lumber.Your risk of exposure varies, depending on how often you do this type of work. To reduce your exposure to these chemicals, work in a well-ventilated area and work with approved safety equipment, such (cont. next pg.) asks that are specifically designed to filter out microscopic particles.
9. Do not operate this machine while tired or under the influence of drugs, alcohol or any medication.



10. Make certain the switch is in the **OFF** position before connecting the machine to the power source.
11. Make certain the machine is properly grounded.
12. Make all machine adjustments or maintenance with the machine unplugged from the power source.
13. Form a habit of checking to see that all extra equipment such as adjusting keys, wrenches, scrap, stock, and cleaning rags are removed away from the machine before turning on.
14. Keep safety guards in place at all times when the machine is in use. If removed for maintenance purposes, use extreme caution and replace the guards immediately when maintenance is complete.
15. Make sure the dust collector is on a flat even surface and the wheels locked in place before use.
16. Check damaged parts. Before further use of the machine, a guard or other part that is damaged should be carefully checked to determine that it will operate properly and perform its intended function. Check for alignment of moving parts, binding of moving parts, breakage of parts, mounting and any other conditions that may affect its operation. A guard or other part that is damaged should be properly repaired or replaced.
17. Provide for adequate space surrounding work area and non-glare, overhead lighting.
18. Keep the floor around the machine clean and free of scrap material, oil and grease.
19. Keep visitors a safe distance from the work area. **Keep children away.**
20. Make your workshop child proof with padlocks, master switches or by removing starter keys.
21. Give your work undivided attention. Looking around, carrying on a conversation and "horse-play" are careless acts that can result in serious injury.
22. Maintain a balanced stance at all times so that you do not fall or lean against the dust collector. Do not overreach or use excessive force to perform any machine operation.
23. Use the right tool at the correct speed and feed rate. Do not force a tool or attachment to do a job for which it was not designed. The right tool will do the job better and safer.
24. Use recommended accessories; improper accessories may be hazardous.
25. Maintain machinery with care. Follow instructions for lubricating and changing accessories.
26. Turn off the machine before cleaning. Use a brush or compressed air to remove dust or debris — do not use your hands.
27. Do not stand on the machine. Serious injury could occur if the machine tips over.
28. Never leave the machine running unattended. Turn the power off and do not leave the machine until it comes to a complete stop.

LAGUNA

Familiarize yourself with the following safety notices used in this manual:

SAFETY GUIDELINES - DEFINITIONS

This manual contains information that is important for you to know and understand. This information relates to protecting YOUR SAFETY and PREVENTING EQUIPMENT PROBLEMS. To help you recognize this information, we use the symbols below. Please read the manual and pay attention to these sections.



Indicates an imminently hazardous situation which, if not avoided, will result in death or serious injury.



Indicates a potentially hazardous situation which, if not avoided, could result in death or serious injury.



Indicates a potentially hazardous situation which, if not avoided, may result in minor or moderate injury.



Used without the safety alert symbol indicates potentially hazardous situation which, if not avoided, may result in property damage.

GENERAL SAFETY RULES



WARNING FAILURE TO FOLLOW THESE RULES MAY RESULT IN SERIOUS PERSONAL INJURY.

FOR YOUR OWN SAFETY, READ AND UNDERSTAND THE INSTRUCTION MANUAL BEFORE OPERATING THE MACHINE. Learn the unit's application and limitations as well as the specific hazards peculiar to it.

KEEP WORK AREA CLEAN. Cluttered areas and benches invite accidents.

DON'T USE IN DANGEROUS ENVIRONMENT. Don't use this unit in damp or wet locations, or expose it to rain. Keep work area well-lighted.

KEEP CHILDREN AND VISITORS AWAY. All children and visitors should be



kept a safe distance from work area.

DISCONNECT UNIT before servicing.

CHECK DAMAGED PARTS. Before further use of the unit, properly repair or replace any part that is damaged.

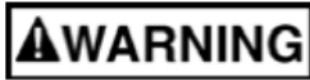

FAILURE TO FOLLOW THESE RULES MAY RESULT IN SERIOUS INJURY.

ADDITIONAL SAFETY FOR DUST COLLECTORS

Intended use. This dust collector is only intended for collecting wood dust and chips from woodworking machines. Do not use this dust collector to collect metal, dirt, pebbles, drywall, asbestos, lead paint, silica, liquids, aerosols, or any flammable, combustible, or hazardous materials.

Hazardous dust. Dust created while using machinery may cause cancer, birth defects, or long-term respiratory damage. Be aware of dust hazards associated with each work piece material, and always wear a NIOSH-approved respirator to reduce your risk.

Dust allergies. Dust from certain woods may cause an allergic reaction in people and animals. Make sure you know what type of wood dust you will be exposed to in case there is a possibility of an allergic reaction.

Wear respirator. Fine dust that is too small to be caught in the filter will be blown into the ambient air during operation. Always wear a NIOSH-approved respirator during operation and for a short time after to reduce your risk of permanent respiratory damage.

Emptying dust. When emptying dust from the collection container, wear a respirator and safety glasses. Empty dust away from ignition sources and into an approved container.

Disconnecting power supply. Turn the switch off, disconnect the dust collector from the power supply, and allow the impeller to come to a complete stop before leaving the machine unattended or doing any service, cleaning, maintenance, or adjustments.

Suspended dust particles and ignition sources. Do not operate the dust collector in areas where explosion risks are high. Areas of high risk include, but are not limited to, areas near pilot lights, open flames, or other ignition sources.

LAGUNA

Fire suppression. Only operate the dust collector in locations that contain a fire suppression system or have a fire extinguisher nearby.

Impeller hazards. Do not place your hands or tools near the open inlet during operation for any reason. The powerful suction could easily cause accidental contact with the impeller, which will cause serious personal injury or damage to the machine. Always keep small animals and children away from open dust collection inlets.

Avoiding sparks. Do not allow steel or rocks to strike the impeller—this may produce sparks. Sparks can smolder in wood dust for a long time before a fire is detected. If you accidentally cut into wood containing tramp metal (nails, staples, spikes, etc.), immediately turn **off** the dust collector, disconnect it from power, and wait for the impeller to stop—then empty the collection container into an approved airtight metal container.

Operating location. To reduce respiratory exposure to fine dust, locate permanently installed dust collectors away from the working area, or in another room that is equipped with a smoke detector. Do not operate the dust collector in rainy or wet locations—exposure to water may create a shock hazard or decrease the life of the machine.

Static electricity. Plastic dust lines generate high amounts of static electricity as dust chips pass through them. Although rare, sparks caused by static electricity can cause explosions or fire. To reduce this risk, make sure all dust lines are thoroughly grounded by using a grounding wire.

Regular cleaning. Regularly check/empty the collection bags or drum to avoid the buildup of fine dust that can increase the risk of fire. Make sure to regularly clean the surrounding area where the machine is operated—excessive dust buildup on overhead lights, heaters, electrical panels, or other heat sources will increase the risk of fire.

CAUTION

This means that if precautions are not heeded, it may result in minor injury and/or possible machine damage.

WARNING

This means that if precautions are not heeded, it may result in serious injury or possibly even death.

**SAVE THESE INSTRUCTIONS.
Refer to them often and use them to instruct others.**

LAGUNA

POWER CONNECTIONS/WIRING DIAGRAM

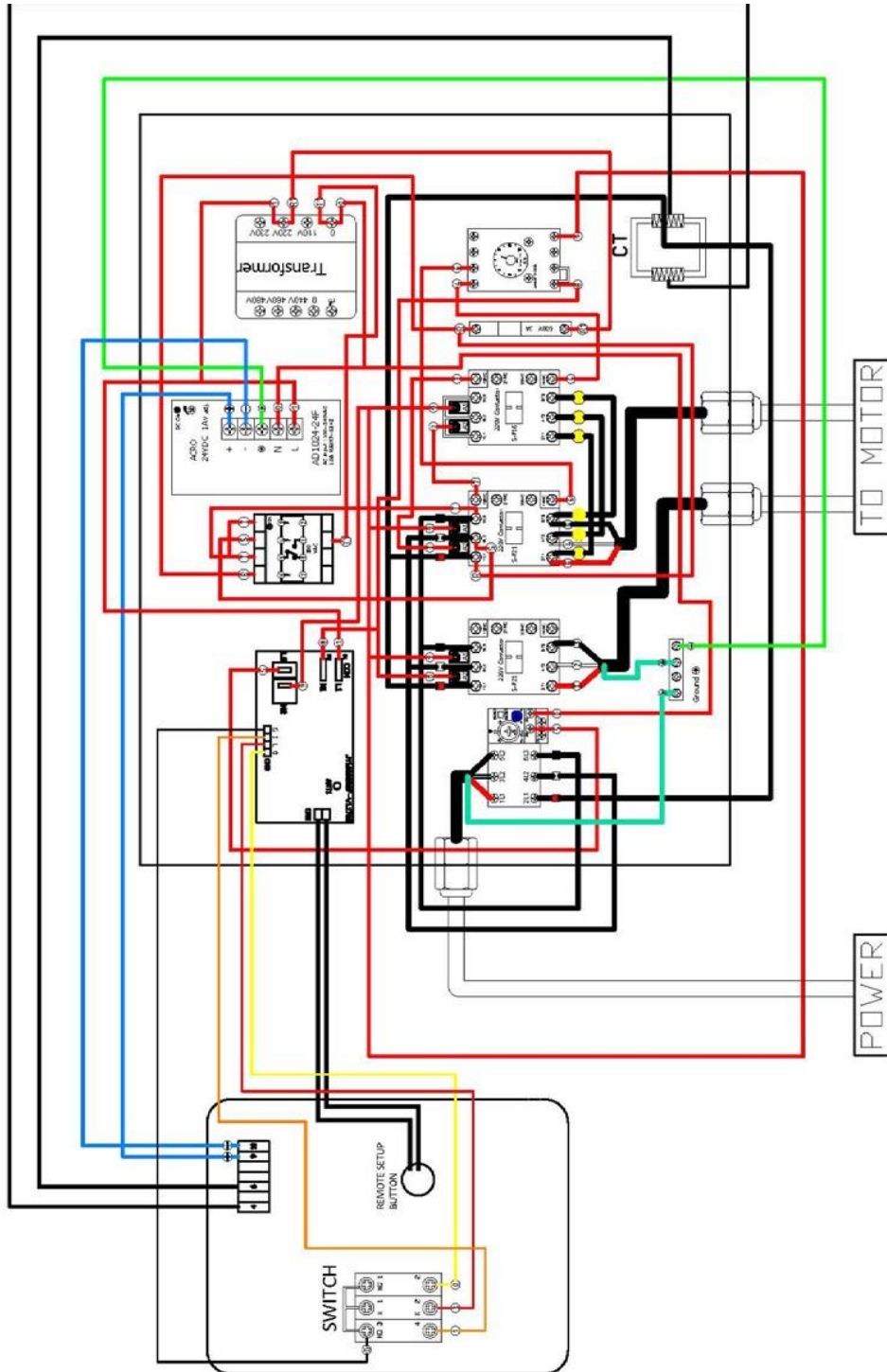



MOTOR SPECIFICATIONS

⚠ DANGER Your machine is wired for 220V, 60 HZ alternating current. Before connecting the machine to the power source, make sure the switch is in the "OFF" position.

GROUNDING INSTRUCTIONS

⚠ DANGER THIS MACHINE MUST BE GROUNDED WHILE IN USE TO PROTECT THE OPERATOR FROM ELECTRIC SHOCK.

1. This appliance must be connected to a grounded metal, permanent wiring system; or an equipment-grounding conductor must be run with the circuit conductors and connected to the equipment-grounding terminal or lead on the appliance.

The installer, such as a qualified electrician, cut (or bend over) and insulate the grounding conductor from a field wiring supply cable.

In the event of certain types of malfunctions or breakdowns, grounding provides a path of least resistance for electric current—in order to reduce the risk of electric shock.

Improper connection of the equipment-grounding wire can result in a risk of electric shock. The wire with green insulation (with or without yellow stripes) is the equipment-grounding wire. If repair or replacement of the power cord or plug is necessary, do not connect the equipment-grounding wire to a live (current carrying) terminal.

Check with a qualified electrician or service personnel if you do not understand these grounding requirements, or if you are in doubt about whether the tool is properly grounded. If you ever notice that a cord or plug is damaged or worn, disconnect it from power, and immediately replace it with a new one.

Full Load amperage Draw

Amp draw at 220V (prewired)..... 28 Amp
Amp draw at 440V 14 Amp

Power Supply Circuit Requirements

The power source circuit for your machine must be grounded and rated for the amperage given below. Never replace a circuit breaker on an existing circuit with one of higher amperage without consulting a qualified electrician to ensure compliance with wiring codes. **If you are unsure about the wiring codes in your area or you plan to connect your machine to a shared circuit, consult a qualified electrician.**

Circuit Size (220V)..... **50 Amp** min.
Circuit Size (440V)..... **30 Amp** min.

LAGUNA

⚠ DANGER

IN ALL CASES, MAKE CERTAIN THE RECEPTACLE IN QUESTION IS PROPERLY GROUNDED. IF YOU ARE NOT SURE, HAVE A QUALIFIED ELECTRICIAN CHECK THE RECEPTACLE.

220V Three-Phase Operation

The motor supplied with your machine is a 220 volt motor. It is shipped ready-to-run for 220 volt operation.

This unit is equipped with a phase shortage protector. When you have connected this unit to the power source and push the on button with no response. Open the control box and change the power cord connections. Swap any two of the connections in the figure below.

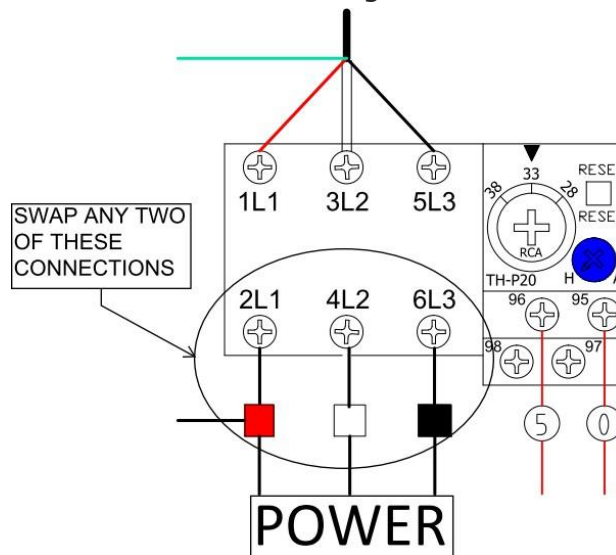

440V Conversion

This unit can be rewired for 440V operation. This rewiring job consists of disconnecting this cyclone from the power source, changing the control box and rewiring the motor.

The conversion components have been supplied with this cyclone. Please make sure to use the components supplied.

When complete, the rewiring job must be inspected by a qualified electrician before the cyclone is connected to the power source. Follow the steps below and refer to the wiring diagrams.

- 1. Disconnect the cyclone from the power source.**
- 2. Open the control box and identify the overload relay and the transformer.**
- 3. Replace the overload relay with the one included in the conversion kit and turn the AMP dial to 14A.**

LAGUNA

4. Move the R1 wire on the transformer from the 220V terminal to the 440V terminal. Remove the T1 wire from the 0 terminal to the top 0 terminal. (See figure below)

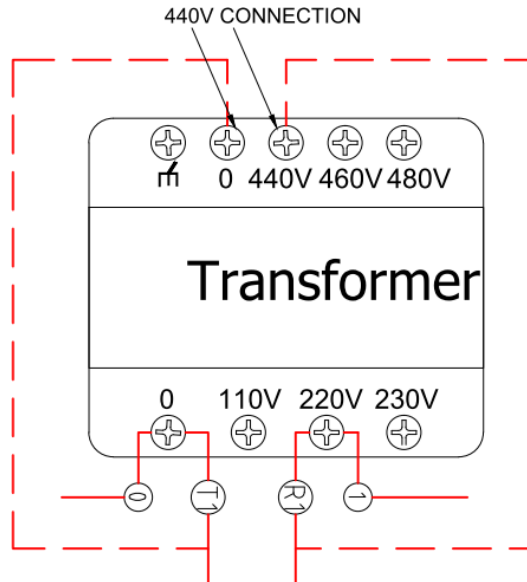

5. Open the motor junction box, rewire the motor terminals for 440V power. (See figure below). Close the motor junction box.

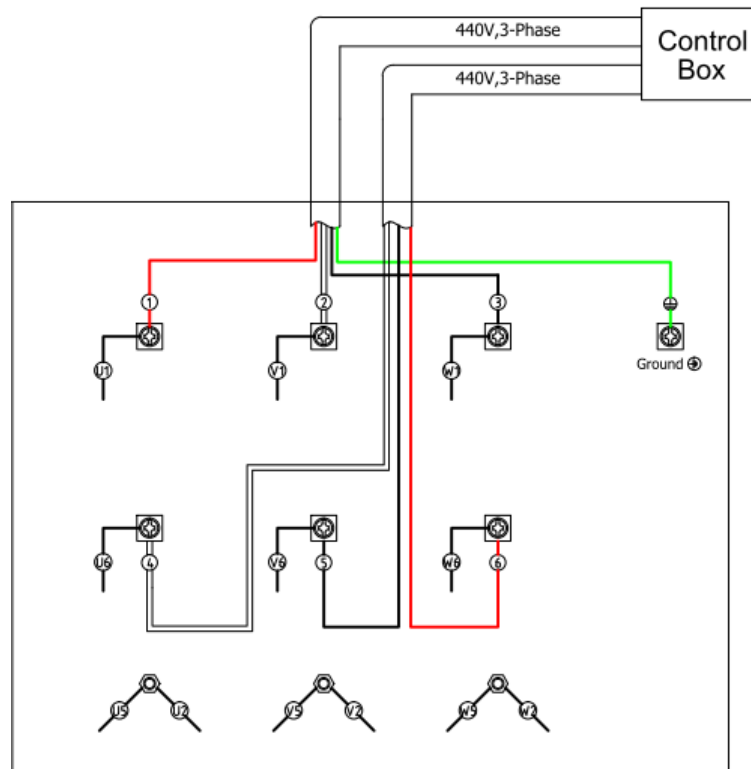

LAGUNA

CONTROL PANEL DESCRIPTION

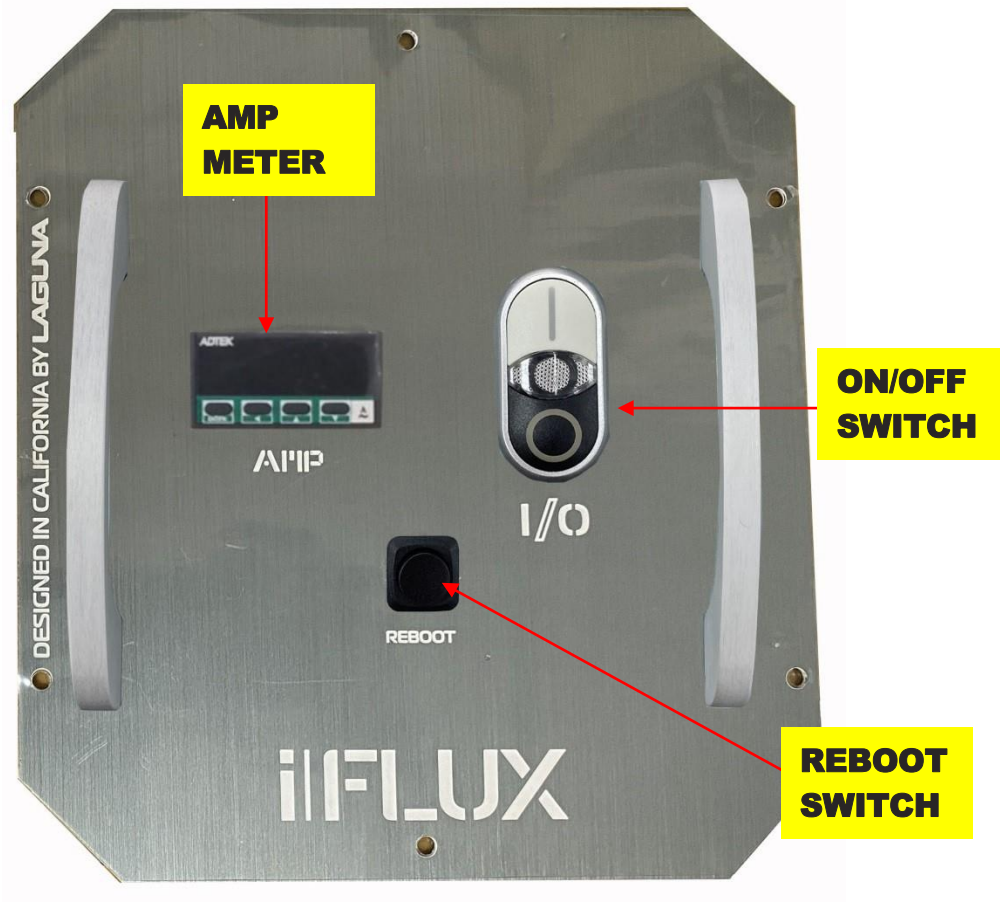

Handheld remote controller

Requires a 12V, type 27A alkaline battery.



*Used to match up a new handheld control with the remote switch



SPECIFICATIONS

Motor Specs:	10 HP
Electrical Specs:	220V/440V / 60Hz / 3PH / 1720 RPM
Running AMP	28A at 220V; 14A at 440V
Air Volume:	5500CFM (cubic feet per minute)
Max. static pressure	6.5 Inches of water
Fan size	22"
Inlet:	Ø15"
Switch	Control box
Machine weight	1069 lbs. (485kgs)
Shipping weight	1113 lbs. (505kgs)

<u>Filter Media</u>	filtering area: 38m ² (409ft ²)
Cartridge Filter	1 Micron D.168xH1800mm Filter bags x40pcs

ASSEMBLY

Tools Required

Open end wrench 12 (not supplied)

Open end wrench 14 (not supplied)

Open end wrench 17 (not supplied)

⚠ DANGER **SEVERE LACERATION HAZARD. TURN THE UNIT "OFF", DISCONNECT THE UNIT** from the power source and wait 2-1/2 minutes to allow time for internal rotating components to stop before installing or removing accessories, before adjusting or changing set-ups, clearing clogs or when making repairs. For your own safety, do not connect the machine to the power source until the machine is completely assembled. Please also make sure that you read and understand the entire instruction manual.

ASSEMBLY TIME ESTIMATE 4 hour to 5 hours

⚠ WARNING DISCONNECT THE MACHINE FROM THE POWER SOURCE!

1. MANUAL BAG CLEANING SHAKER

Take the housing assembly with the top filter bags; the shaker has already been set in place inside the filter bags. (Fig. 1) You need to lift the upper frame (Fig. 3) and take the triangular tips and bolt onto the upper frame using the hex bolts 3/8", flat washers 3/8" and lock nuts 3/8". (Fig. 2) Do not completely fasten, as you will need it to be movable to clean the filter bags. You will need to do the same for the opposite side.



2. TOP FILTER BAG SUPPORT RODS

With the help of three other people; you need to lift the upper frame and insert the top filter bag support rods (Fig. 4). After inserting it into the upper frame, make sure to use the hex bolts 5/16" to tighten each rod in place. Each rod needs to be secured in two places, one on the top (Fig. 5) and one at the bottom (Fig. 6) Check each filter bag for any loose connections (Fig. 7) to prevent any dust leakages.

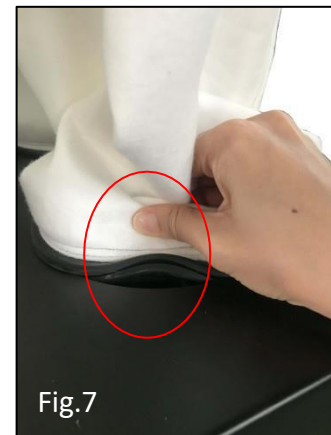

3. ASSEMBLE INTAKE FLANGE TO MOTOR HOUSING

Take the intake flange and assemble to the motor housing using hex bolts 3/8" and flat washers 3/8".

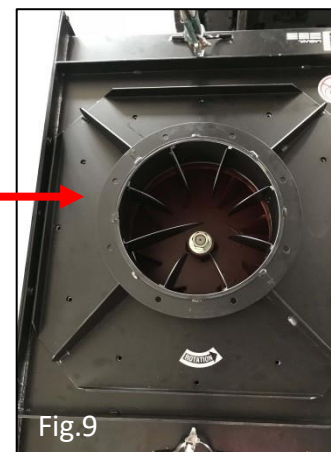
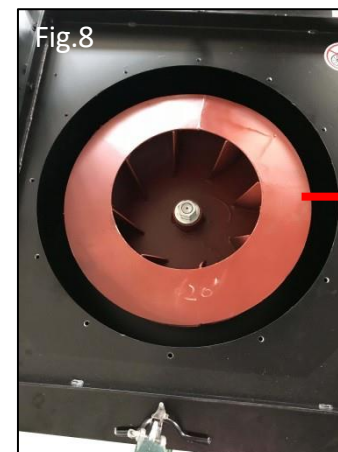

4. ASSEMBLE INTAKE ADAPTER TO THE FLANGE

Take the intake adapter with five 5" ports and assemble to the intake flange.



5. ASSEMBLE MOTOR HOUSING TO FILTER BAG HOUSING

Use a crane to lift the motor housing up to about 5 feet high. Be careful that the motor housing does not swing around and cause injury. Use a fork lift and place a wooden pallet on the forks that will be used to lift the filter bag housing. Lift to the same height as the motor housing at 5 feet (Fig. 11). Use the hex bolts 3/8", flat washers 3/8" and lock nuts 3/8" to assemble the two together.



6. ASSEMBLE LEG STANDS

Take the four leg stands and assemble to each corner using the hex bolts 3/8" and flat washers 3/8" (Fig. 12 and Fig. 13). It does not matter which After you have completed assembling them, make sure to take the vibration pads (Fig. 14) and set underneath each leg before lowering forklift and crane to set the unit on the ground.



7. ASSEMBLE CONTROL PANEL

Take control panel and assemble to the motor housing using hex bolts 3/8", flat washers 3/8" and lock nut 3/8". (Fig.15)

There are three points on the top of the control panel to secure with the hex bolts. And two points on the leg stand to secure with the hex bolts. (Fig. 16)
Make you tighten and fasten to secure the control panel in place.

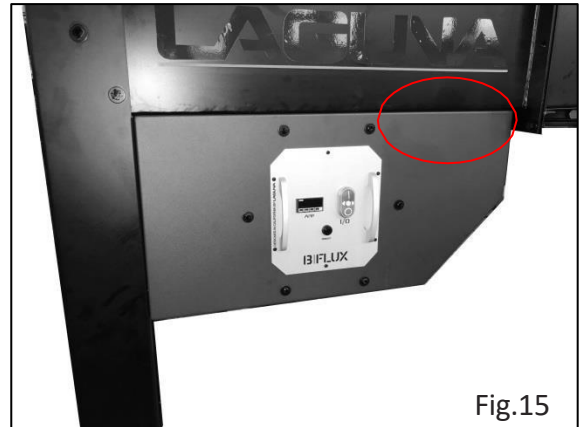

Fig.15

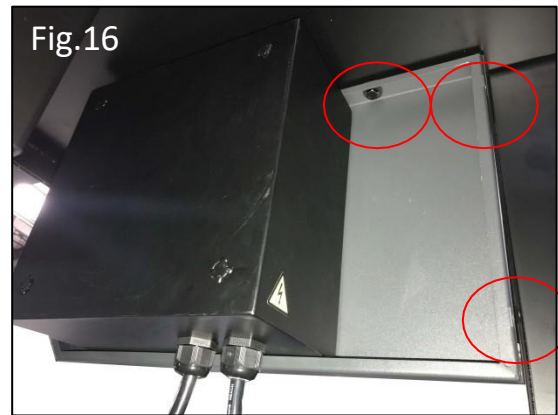

Fig.16

8. ASSEMBLE WHEELS ONTO DRUM

Take the eight wheels and assemble to the bottom of each drum (four each) using hex bolts 5/16" and flat washers 5/16". (Fig. 17 and Fig. 18)

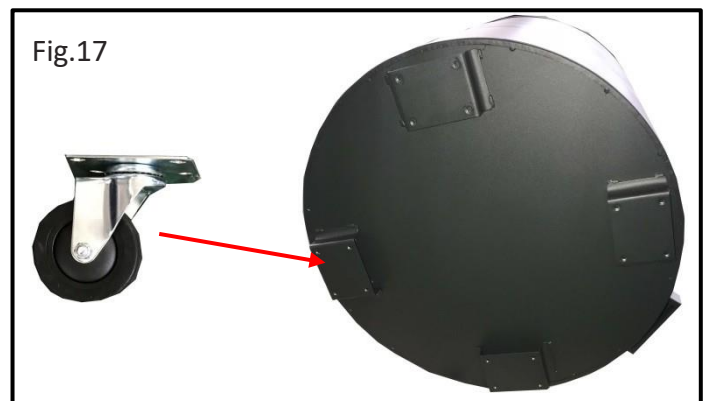

Fig.17

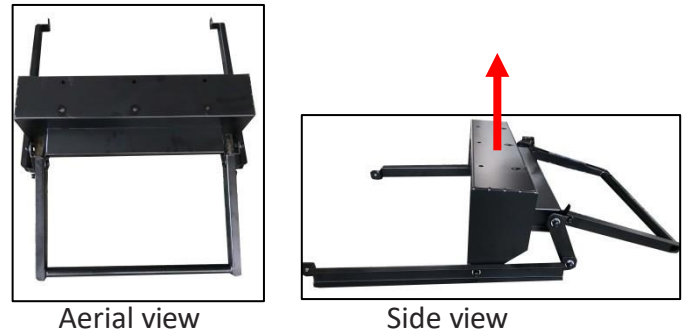
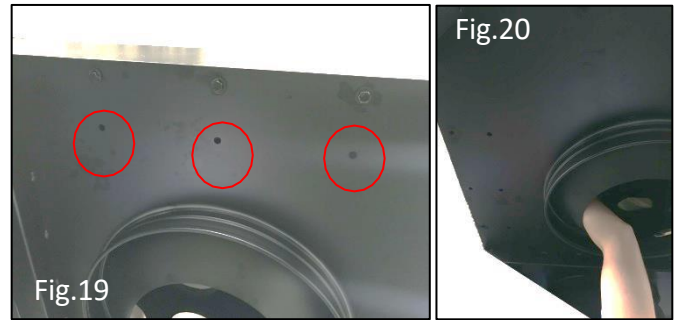

Fig.18

9. ASSEMBLE EZ LIFT HANDLE

First remove the three hex bolts 3/8", flat washers 3/8" and lock 3/8" from underneath the lower filter housing. Set aside for use when you assemble the ez lift handle. The inner row of bolts will need to bolt on with one hand/arm reaching in from inside the filter housing. Do the same for the other handle. (Fig. 19 and Fig. 20)

Take the ez lift handle kit, both handles are the same it does not matter which one you take; make sure you have the right side facing upwards to match the bolt holes on the filter housing. (Fig. 21)



10. ASSEMBLE EZ LIFT HANDLE TO DRUM LID

One person must stand in the front where the handle kit is, and hold up the two side bars. Take note that the handle must be in the lower position, push the drum kit underneath the filter housing to make the attachment (Fig. 22). Use the hex bolts 3/8" flat washers and lock nuts 3/8" to assemble the side bar to the drum lid spring support base on each side (Fig. 23). Do the same for the other drum.



LAGUNA

11. HOOK UP THE CLOTH CONNECTION

Attach the black cloth connection to the rim under the filter housing. Use the band clamp to secure in place. Do the same for the other drum. (Fig.24 and Fig. 25)

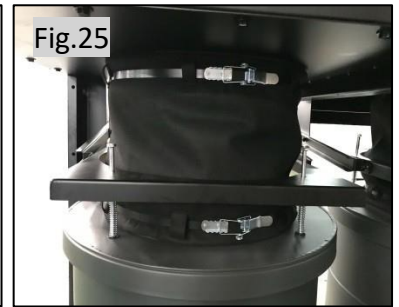

12. PLASTIC BAG INTO DRUMS

Put the plastic bags into the drums before closing the drums in place.

Make sure to keep the handle closed during operation. When left open, there will be air leakage and will cause the performance of the unit to come down. Furthermore, the dust will become airborne and create a mess in your working environment.



Closed = Handle down position



Open = Handle up position

ROUTINE INSPECTION

It is a good idea to routinely inspect any quality woodworking tool in order to keep it in optimum condition. This includes inspecting all hardware for tightness, ensuring the filter is clean, and cleaning debris and grime from any surfaces and moving parts.



TROUBLESHOOTING GUIDE

Symptom	Possible Cause	Possible Solution
Machine does not start or a breaker trips.	Power supply switched OFF or is faulty.	Ensure power supply is ON and has the correct voltage.
	Wall fuse/circuit breaker is blown/tripped.	Ensure adequate circuit size; install inlet restrictor, replace weak breaker.
	Incorrectly wired motor connection.	Rewire or call certified service technician or electrician.
	On-board circuit breaker is tripped.	Allow motor to cool, improve ventilation, press reset button.
	Wiring is open/has high resistance.	Check for broken wires or poor connections, repair as necessary.
	Faulty power switch.	Replace switch.
Excessive vibration or noise during operation.	Motor is at fault.	Test/repair/replace.
	Loose component.	Inspect and tighten all bolts/nuts.
	Loose or broken motor mount.	Tighten or replace as needed.
	Motor fan hitting fan cover.	Check fan and cover; replace as needed.
Loud, repetitive noise, or excessive vibration coming from cyclone	Bad motor bearings.	Rotate shaft manually, check for grinding or loose shaft, replace bearings if needed.
	Machine is on uneven surface.	Stabilize on a flat surface.
	Damaged/Unbalanced impeller.	Inspect impeller for dents, bends, loose fins. Replace if needed.
	Loose connections.	Check and re-tighten all fasteners.
	Impeller is loose.	Replace the motor and impeller.
Motor fan hitting fan cover.	Check fan and cover; replace as needed.	

LAGUNA

<p>Dust collector does not adequately collect dust or chips; poor performance.</p>	<p>Canister end bag is full.</p> <p>Filter is dirty.</p> <p>Restricted duct line.</p> <p>Suction route is too long or has too many sharp bends.</p> <p>Wet lumber is clogging ducts.</p> <p>Leaks in the duct work or too many open ports.</p> <p>Inadequate velocity in the main suction line.</p> <p>Wrong size ducting/ports used.</p>	<p>Empty canister end bag.</p> <p>Clean filter.</p> <p>Clean inlet adapter.</p> <p>Move machine closer to the point of suction, and rerun ducts to eliminate sharp bends.</p> <p>Use lumber with less than 20% moisture content.</p> <p>Repair all duct leaks and close any ports not being used.</p> <p>Increase velocity by opening 1 or 2 more blast gates to different branch lines.</p> <p>Re-size and re-install ducts and fittings.</p>
<p>Sawdust being blown into the air from the dust collector</p>	<p>Band clamp or end bag is not secure.</p> <p>Loose or damaged seals.</p>	<p>Re-install ensuring a tight fit.</p> <p>Replace seals and gaskets.</p>

LAGUNA

Parts Breakdown/Exploded View

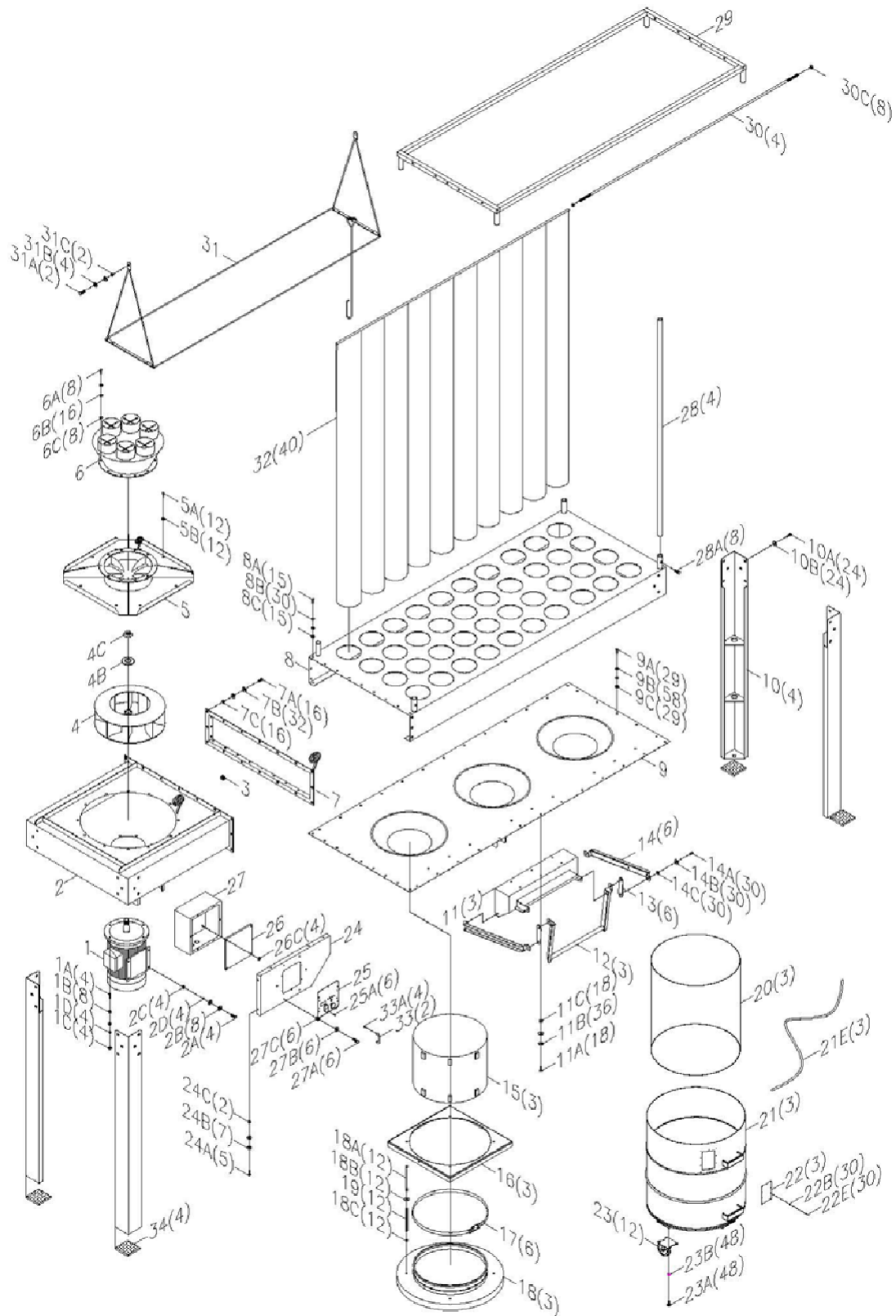

LAGUNA

Part List

Ref No	Part number	Part Name	Description	QTY
1	PDCIF102203-1	MOTOR	10HP/220V/440V/60HZ/3 PHASE	1
1A	PDCIF102203-1A	HEX BOLT	5/8"*2"	4
1B	PDCIF102203-1B	FLAT WASHER	5/8"*OD40*3t	8
1C	PDCIF102203-1C	HEX NUT	5/8"	4
1D	PDCIF102203-1D	LOCK WASHER	5/8"	4
2	PDCIF102203-2	BLOWER		1
2A	PDCIF102203-2A	HEX BOLT	1/2"*1-1/2"	4
2B	PDCIF102203-2B	FLAT WASHER	1/2"*OD28*3t	8
2C	PDCIF102203-2C	HEX NUT	1/2"	4
2D	PDCIF102203-2D	LOCK WASHER	1/2"	4
3	PDCIF102203-3	PLUG	25*25	1
4	PDCIF102203-4	IMPELLER/FAN	26"	1
4B	PDCIF102203-4B	FAN WASHER	1*OD58*3t	1
4C	PDCIF102203-4C	NUT	1-1/16"	1
5	PDCIF102203-5	INTAKE COVER		1
5A	PDCIF102203-5A	HEX BOLT	3/8"*3/4"	12
5B	PDCIF102203-5B	FLAT WASHER	3/8"*OD23*2t	12
6	PDCIF102203-6	INTAKE ADAPTER	15" BY 5" X 6 PORTS	1
6A	PDCIF102203-6A	HEX BOLT	3/8"*1"	8
6B	PDCIF102203-6B	FLAT WASHER	3/8"*OD23*2t	16
6C	PDCIF102203-6C	LOCK NUT	3/8"	8
7	PDCIF102203-7	HOUSING FLANGE		1
7A	PDCIF102203-7A	HEX BOLT	3/8"*1"	16
7B	PDCIF102203-7B	FLAT WASHER	3/8"*OD23*2t	32

LAGUNA

Part List

Ref No	Part number	Part Name	Description	QTY
7C	PDCIF102203-7C	LOCK NUT	3/8"	16
8	PDCIF102203-8	TOP BAG HOUSING		1
8A	PDCIF102203-8A	HEX BOLT	3/8"*1"	15
8B	PDCIF102203-8B	FLAT WASHER	3/8"*OD23*2t	30
8C	PDCIF102203-8C	LOCK NUT	3/8"	15
9	PDCIF102203-9	LOWER HOUSING		1
9A	PDCIF102203-9A	HEX BOLT	3/8"*1"	29
9B	PDCIF102203-9B	FLAT WASHER	3/8"*OD23*2t	58
9C	PDCIF102203-9C	LOCK NUT	3/8"	29
10	PDCIF102203-10	LEG STAND		4
10A	PDCIF102203-10A	HEX BOLT	3/8"*3/4"	24
10B	PDCIF102203-10B	FLAT WASHER	3/8"*OD23*2t	24
11	PDCIF102203-11	EZ LIFT HANDLE SUPPORT BASE		3
11A	PDCIF102203-11A	HEX BOLT	3/8"*1"	18
11B	PDCIF102203-11B	FLAT WASHER	3/8"*OD23*2t	36
11C	PDCIF102203-11C	LOCK NUT	3/8"	18
12	PDCIF102203-12	EZ LIFT HANDLE		3
13	PDCIF102203-13	EZ LIFT SUPPORT BRACE		6
14	PDCIF102203-14	EZ LIFT HANDLE SIDE BRACKET		6
14A	PDCIF102203-14A	THREADED BOLT	3/8"*7/8"	30
14B	PDCIF102203-14B	FLAT WASHER	3/8"*OD20*1t	30
14C	PDCIF102203-14C	LOCK NUT	3/8"	30
15	PDCIF102203-15	CONNECTION CLOTH	Ø500*380MM	3
16	PDCIF102203-16	DRUM LID SPRING SUPPORT BASE		3

LAGUNA

Part List

Ref No	Part number	Part Name	Description	QTY
17	PDCIF102203-17	SPRING CLAMP	Ø500	6
18	PDCIF102203-18	DRUM LID		3
18A	PDCIF102203-18A	THREADED BOLT	3/8"*7"	12
18B	PDCIF102203-18B	FLAT WASHER	3/8"*OD23*2t	12
18C	PDCIF102203-18C	LOCK NUT	3/8"	12
19	PDCIF102203-19	SPRING		12
20	PDCIF102203-20	LOWER PLASTIC BAG	Ø740mm*1.3M	3
21	PDCIF102203-21	64 GALLON DRUM		3
21E	PDCIF102203-21E	R-SHAPED GASKET	2.1M	3
22	PDCIF102203-22	WINDOW		3
22B	PDCIF102203-22B	FLAT WASHER	2.7*OD6*1.5t	30
22E	PDCIF102203-22E	RIVET	3-2	30
23	PDCIF102203-23	CASTER	4"	12
23A	PDCIF102203-23A	HEX BOLT	5/16"*3/4"	48
23B	PDCIF102203-23B	FLAT WASHER	5/16"*OD18*2t	48
24	PDCIF102203-24	CONTROL BOX SUPPORT PLATE		1
24A	PDCIF102203-24A	HEX BOLT	3/8"*1"	5
24B	PDCIF102203-24B	FLAT WASHER	3/8"*OD23*2t	7
24C	PDCIF102203-24C	LOCK NUT	3/8"	2
25	PDCIF102203-25	CONTROL PANEL		1
25A	PDCIF102203-25A	PHLIP HD BOLT	M4*10	6
26	PDCIF102203-26	CAPACITOR SUPPORT PLATE		1
26C	PDCIF102203-26C	HEX BOLT	1/4"	4
27	PDCIF102203-27	CONTROL BOX		1

LAGUNA

Part List

Ref No	Part number	Part Name	Description	QTY
27A	PDCIF102203-27A	HEX BOLT	1/4"*3/4"	6
27B	PDCIF102203-27B	FLAT WASHER	1/4"*OD19*2t	6
27C	PDCIF102203-27C	LOCK NUT	1/4"	6
28	PDCIF102203-28	TOP FILTER BAG SUPPORT ROD		4
28A	PDCIF102203-28A	HEX BOLT	5/16"*3/4"	8
29	PDCIF102203-29	TOP FILTER BAG UPPER FRAME		1
30	PDCIF102203-30	BAG HANGER		4
30B	PDCIF102203-30B	FLAT WASHER	3/8"*OD23*2t	16
30C	PDCIF102203-30C	LOCK NUT	3/8"	8
30C-1	PDCIF102203-30C-1	NUT	3/8"	8
31	PDCIF102203-31	SHAKER BAR		1
31A	PDCIF102203-31A	HEX BOLT	3/8"*2"	2
31B	PDCIF102203-31B	FLAT WASHER	3/8"*OD23*2t	4
31C	PDCIF102203-31C	LOCK NUT	3/8"	2
32	PDCIF102203-32	TOP FILTER BAG	1 MICRON Ø168MM*1.8M	40
33	PDCIF102203-33	HANDLE	CONTROL PANEL	2
33A	PDCIF102203-33A	PHILIP HD BOLT	M4*6MM	4
34	PDCIF102203-34	VIBRATION ABSORBENT PAD	1/2*5*7	4
35	PDCIF102203-35	CAP	5"	5

LAGUNA

WARRANTY & REGISTRATION

Thank You!

Welcome to the Laguna Tools® group of discriminating industrial machinery owners. We understand that you have a choice of where to purchase your machines and appreciate the confidence you have in the Laguna Tools® brand.

Through hands-on experience, Laguna Tools® is constantly working hard to make innovative, precision products. Products that inspire you to create works of art are a joy to operate and encourage your best work.

Laguna Tools®
Imagination, Innovation, and Invention at Work

Warranty & Registration

Every product sold is warranted to be free of manufacturer's defective workmanship, parts, and materials. For any questions about this produce, the intended use or what it was designed for, customer service, or replacement parts, please contact our customer service department:

Laguna Tools® Customer Service
744 Refuge Way, Grand Prairie, Texas 75050, USA
1-800-234-1976
customerservice@lagunatools.com
www.lagunatools.com/why/customer-service/
8AM. To 5PM PSF. Monday through Friday

For warranty claims or to report damage upon receiving-please reach out to our warranty department:

Laguna Tools® Warranty Service
744 Refuge Way, Grand Prairie, Texas 75050, USA
1-800-234-1976
customerservice@lagunatools.com
www.lagunatools.com/policies/warranty
8AM to 5PM PST, Monday through Friday

Registration

To prevent voiding this warranty, all products sold must be registered within thirty (30) days of receiving the product. Registering the product will enable the original purchaser to receive notifications about important product changes, receive customer service, and be able to file a warranty claim against defective workmanship, parts, or materials.



Who is Covered

The applicable warranty covers only the initial purchaser of the product from the date of receiving the product. To file such claims, the original purchaser must present the original receipt as proof of purchase.

What is Covered

The warranty covers any defects in the workmanship of all parts and materials that make up the machine unless otherwise specified. Any part determined by Laguna Tools® to have a defect will be repaired or replaced (and shipped), without charge. The defective item/part must be returned to Laguna Tools® with the complaint and proof of purchase in the original packaging that it was received in. In the event the item/part is determined to be not covered by this warranty, the customer will be responsible for the cost to replace the item/part and all related shipping charges

Warranty Limitations

This limited warranty does not apply to natural disasters, acts of terrorism, normal wear and tear, product failure due to lack of maintenance or cleaning, damage caused by accident, neglect, or lack-of inadequate dust collection. The warranty may be voided against proof of misuse/abuse, damage caused where repair or alterations have been made or attempted by others, using the product for purposes other than those described as intended use (unless with consent by Laguna Tools®), modification to the product, or use with an accessory that was not designed for the product. It is the responsibility of the user to understand basic machinery settings and procedures and to properly maintain the equipment in accordance with the standards provided in this manual.

Length of Warranty

Machines sold for either commercial or industrial use have a one-year warranty. Wearable parts like throat plates, bandsaw guides, etc., have a ninety-day warranty.

Table A-1 Warranty Lengths

1 Year – Machines Sold for Commercial or Industrial Use
1 Year – Blades and Accessories outside of Machine Options
90 Days – Wearable Parts

Aside from being free of defects upon receiving, consumable parts, like cutters and abrasives, are not covered by this warranty unless otherwise stated by Laguna Tools®. These parts are designed to be used at the expense of the operator and are available for replacement or inventory purchase. The determination of a consumable part will be made on a case-by-case basis by Laguna Tools®.

Shipping Damage

Laguna Tools® is not responsible for damage or loss caused by a freight company or other circumstances not in the direct control of Laguna Tools®. All shipping-related claims for loss or damage to goods must be made to Laguna Tools® within twenty-four hours of delivery.

How to Receive Support

To file a warranty-claim please contact the warranty department at 1-800-234-1976. To receive customer service or technical support please contact the customer service or technical support please contact the customer service department at 1-800-332-4049. Parts, under warranty, are shipped at the expense of Laguna Tools® either by common carrier, FedEx ground services or similar method. Technical support to install replacement parts is primarily provided by phone, fax, email, or the Laguna Tools® Customer Service Support Website.



© 05/2023 Laguna Tools, Inc.



NOTE



NOTE

LAGUNA

www.lagunatools.com

060324