

THE LAGUNA SMART SHOP® FIBER LASER FC-T

LAGUNA

FIBER LASER FC-T 2026

STAND-ALONE PIPE AND TUBE PRODUCTION PERFECTION



THE LAGUNA SMART SHOP® FIBER LASER FC-T

The Laguna SmartShop® Laser FC-T is a high performance, heavy duty Fiber Laser cutting system for Pipe and Tube Production. The ultra rigid frame provides for a stable platform that ensures accuracy and high speed processing. You can choose from several Optical power supplies.

MACHINE SPECIFICATION:

- **Pipe and Tube Capacity 20' Long**
- **Heat Treated and Stress relieved Frame**
- **Fiber Laser Power Options: 3KW, and 6KW Available**
- **.60" – 9.4" Diameter Capacity on Round Pipe**
- **.80"-9.4" Diameter Capacity on Square Stock**
- **Bevel Cutting Available**
- **BOCI Closed Loop Cutting Head, Real time Feedback to the Controller.**
- **Automatic Center Adjustment for all shapes**
- **Automated Height Control with Edge finding Capabilities**
- **Yaskawa Servo systems for all Axis**
- **Rack and Pinion Drive System**
- **Climate Controlled Electrical Cabinet**
- **Comprehensive Maintenance Packages Available with Laguna Care**



THE LAGUNA SMART SHOP® FIBER LASER FC-T

Average Maximum Cut Thickness by Power Supply:

LASER POWER	CARBON STEEL	STAINLESS STEEL	ALUMINUM	COPPER	BRASS
3KW	0.780 INCH	0.310 INCH	0.230 INCH	0.110 INCH	0.190 INCH
6KW	0.980 INCH	0.700 INCH	0.550 INCH	0.190 INCH	0.390 INCH

POWER REQUIREMENTS:

Power Supply Wattage	Optic Transformer Amperage	Phase	Nitrogen Assist Gas	Oxygen Assist Gas	Clean Dry Compressed Air
480V,3KW *	60 Amps	3 Phase	50-300 PSI	30-100 PSI	7-9 CFM, 90 PSI
220V,3KW *	125 Amps	3 Phase	50-300 PSI	30-100 PSI	7-9 CFM, 90 PSI
480V,6KW *	80 Amps	3 Phase	50-300 PSI	30-100 PSI	7-9 CFM, 90 PSI
220V,6KW *	208 Amps	3 Phase	50-300 PSI	30-100 PSI	7-9 CFM, 90 PSI

Note: * 3KW and up require an additional 208-240V.40A,3PH circuit for Servo's

- * On Site Commissioning and Training Available.**
- * Lifetime Machine Technical Support.**
- * Laguna-Care Maintenance Programs Available.**



INTELLIGENT CUTTING HEAD by BOCI:

- **Real Time Closed-Loop Feedback** from built-in sensors provides **Intelligent Monitoring for Rapid Diagnostics of Problems with Proactive Warnings.**
- **Lens Temperature Detection** for **Contamination / Damage Detection.**
- **Collision Detection** **Minimizes Losses and enables Rapid Production Recovery.**
- **Rapid Focus-Collimation Response** Ensures a more **Precise and Consistent Cut.**
- **2 Lower Protective Lenses** to Provide added **Shielding for the Focal Lens Set.**
- **Optimized Cooling System** covers **90% of the Optical Path** Provides **Full Body Cooling for the Cutting Head.**



LAGUNA LASER

LAGUNATOOLS.COM

800.234.1976

THE LAGUNA SMART SHOP® FIBER LASER FC-T

HIGH PERFORMANCE FIBER LASER:

Our Optical Supply Delivers performance, Consistency, and Cost Efficiency in the Most Demanding Industries or Educational Facilities. Laguna can Provide Solutions to Drive Success while Optimizing your operational Costs.

FEATURES:

- **Global Industrial Fiber Laser Manufacturer**
- **Consistent Beam Quality for repeatable cutting performance**
- **Power Stability Maintains the Output within $\pm 1\%$ Ensuring Consistent Results**
- **Remote Diagnostics with the Machine and Fiber Optic Power Supply**
- **Connections for Optical interface information through the machines PC and with Bluetooth.**
- **Reliability and Efficiency through a High Electro-to-Optical Conversion.**
- **3KW and Larger have the added Back Reflection Protection for Highly Reflective Materials like Copper and Brass.**



THE LAGUNA SMART SHOP® FIBER LASER FC-T

SIDE VIEW

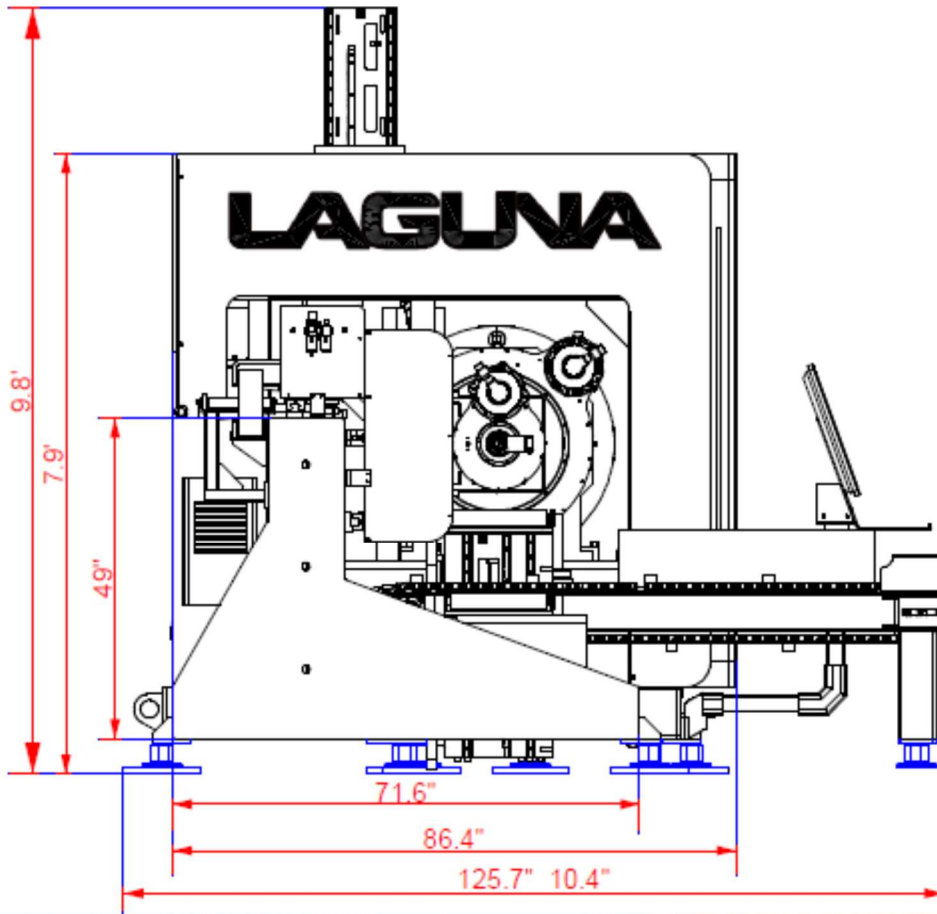

FRONT VIEW

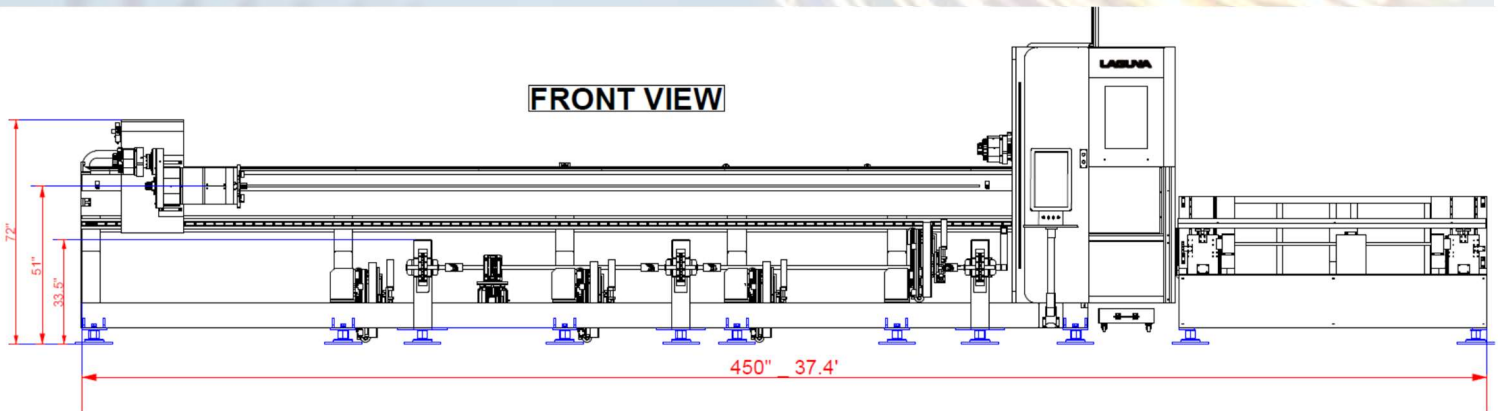

LAGUNA LASER
LAGUNATOOLS.COM 800.234.1976