

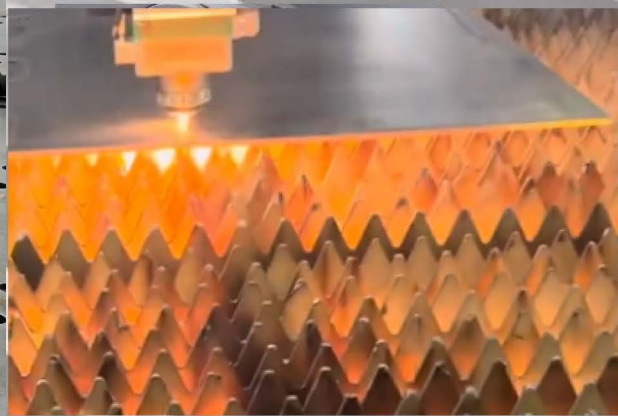

LAGUNA

SMARTSHOP®

LASER | FC

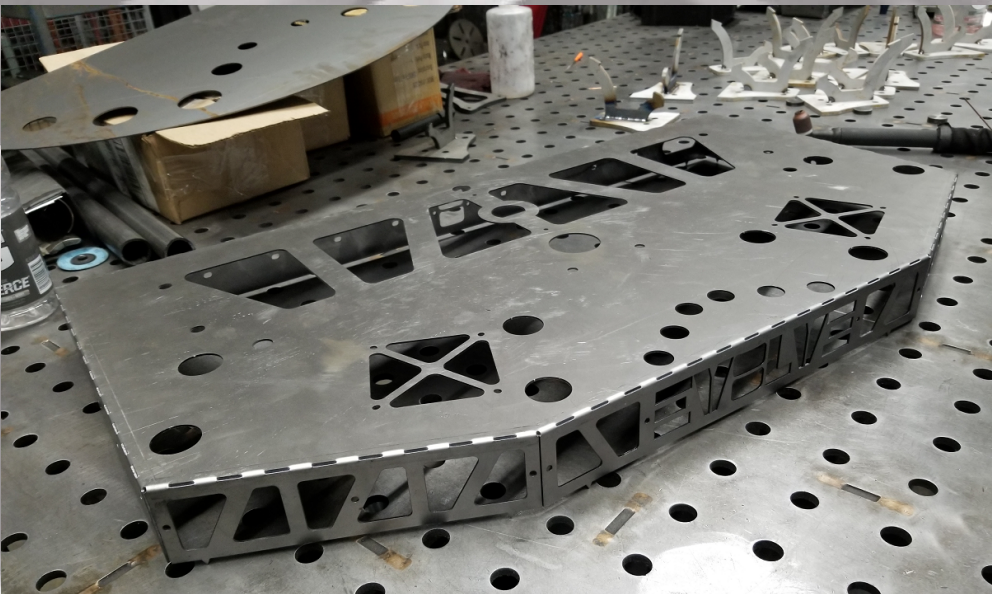

THE LAGUNA SMARTSHOP® LASER | FC

The Laguna SmartShop® Laser FC is a high performance, heavy duty fiber laser cutting system. It's Compact Footprint is perfect for a shop with limited floor space. The ultra rigid frame and gantry provide for a stable platform that ensures accuracy and high speed processing. You can choose from several Optical power supplies and Powers.

FC FIBER LASER SPECIFICATION:

- *FC Table Sizes 5'x10' and 6'x13' Available.
- *Laser Power Options: 2KW and 3KW
- *BOCI Closed Loop Cutting Head, Real Time Diagnostics to the control software.
- *Central Oiling System for Precision Linear Bearings on all Axis.
- * Down Draft Table for Fume Extraction.
- * Models with Full Enclosure are also Available.

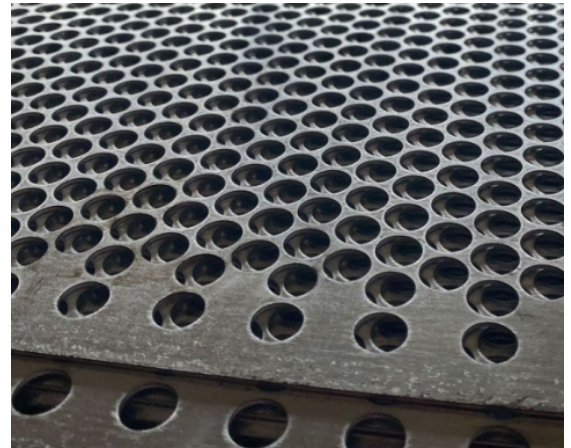

LAGUNA CARE



- * Heat-treated and stress relieved Frame.
- * WiFi capable.
- * Yaskawa servo drive package.
- * Automatic Cutting Head height Control.
- * Industrial Chiller, Cooling system for laser source and optics.
- * Automatic edge finding.
- * Software Controlled Focal Adjustments.
- * Batch and Nesting Production.
- * Rack and pinion drive system.
- * Optical Power Supply is Bluetooth Capable.
- * Control Cabinet Climate Controlled.
- * Several Optical Supplies Available.
- * Comprehensive Maintenance Packages with Laguna-Care.

LAGUNA LASER

LAGUNATOOLS.COM

800.234.1976

Average Maximum Cut Thickness's

This Chart is an Estimate of the Depth of Cut Permissible with the Wattage Purchased

Power supply Wattage	Carbon Steel	Stainless Steel	Aluminum	Copper	Brass
2,000 W, 2KW *	0.620"	0.230"	0.150"	0.050"	0.070"
3,000 W, 3KW **	0.780"	0.310"	0.230"	0.110"	0.190"

Notes:

* 2KW is a 220v,3 phase machine.

** 3KW has Back Reflection Protection the 2KW does not.

*** Open Table Fiber Lasers are Limited to 3KW power Maximum by Law.



LAGUNA CARE

Maintenance Packages that Keeps
Your Investment in Production.

LAGUNA LASER

Power Requirements:

Power supply Wattage	Power Supply Voltage	Power Supply Amperage	Phase	Oxygen Assist Gas	Nitrogen Assist Gas	Clean Dry Shop Air
2,000 W, 2KW	208-240V	60 Amps	1 Phase	30-100 PSI	50-200 PSI	7-9CFM, 90PSI
3,000 W, 3KW	440-480V	60 Amps	3 Phase	30-140 PSI	50-300 PSI	7-9CFM, 90PSI
Low Volt 3KW	208-240V	125 Amps	3 Phase	30-140 PSI	50-300 PSI	7-9CFM, 90PSI

Note: 3KW Power supplies require an additional 208-240V.40A,3PH circuit for Servo's if using 480V for Optical Power Supply.

- * On Site Commissioning and Training Available.**
- * Life Time Machine Technical Support.**
- * Laguna-Care Maintenance Programs Available.**



LAGUNA LASER

LAGUNATOOLS.COM

800.234.1976

THE LAGUNA SMART SHOP® FIBER LASER FC

INTELLIGENT CUTTING HEAD by BOCI:

- **Real Time Closed-Loop Feedback from built-in sensors provides Intelligent Monitoring for Rapid Diagnostics of Problems with Proactive Warnings.**
- **Lens Temperature Detection for Contamination / Damage Detection.**
- **Collision Detection Minimizes Losses and enables Rapid Production Recovery.**
- **Rapid Focus-Collimation Response Ensures a more Precise and Consistent Cut.**
- **2 Lower Protective Lenses to Provide added Shielding for the Focal Lens Set.**
- **Optimized Cooling System covers 90% of the Optical Path Provides Full Body Cooling for the Cutting Head.**

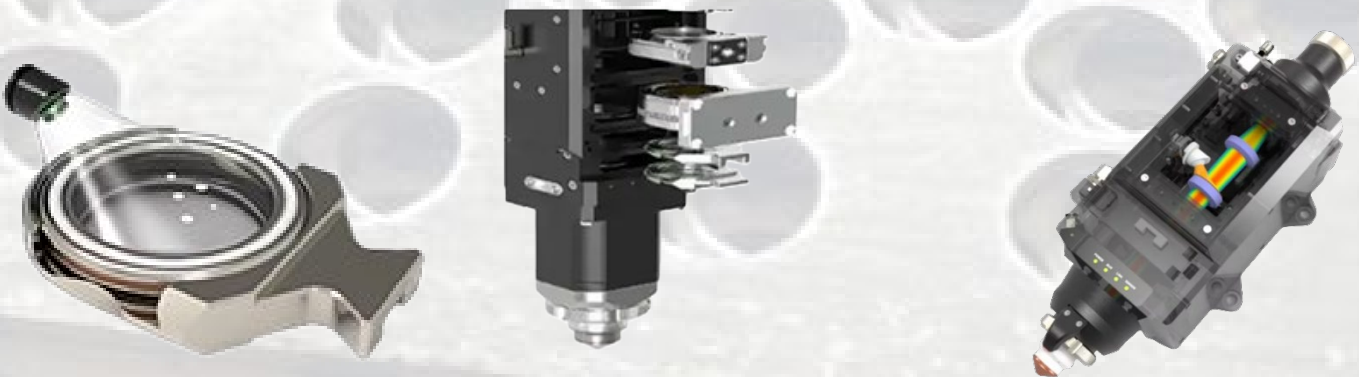

LAGUNA LASER

LAGUNATOOLS.COM

800.234.1976

THE LAGUNA SMART SHOP® FIBER LASER FC

HIGH PERFORMANCE FIBER LASER:

Our Optical Supply Delivers Performance, Consistency, and Cost Efficiency in the Most Demanding Industries or Educational Facilities. Laguna can Provide Solutions to Drive Success while Optimizing your Operational Costs.

FEATURES:

- **Global Industrial Fiber Laser Manufacturer**
- **Consistent Beam Quality for repeatable cutting performance**
- **Power Stability Maintains the Output within $\pm 1\%$ Ensuring Consistent Results**
- **Remote Diagnostics with the Machine and Fiber Optic Power Supply**
- **Connections for Optical interface information through the machines PC and with Bluetooth.**
- **Reliability and Efficiency through a High Electro-to-Optical Conversion.**
- **3KW and Larger have the added Back Reflection Protection for Highly Reflective Materials like Copper, Brass, and Nickel.**



LAGUNA LASER

LAGUNATOOLS.COM

800.234.1976

THE LAGUNA SMARTSHOP[®] LASER | FC

5'x10' FC Footprint

7/29/2025, REV1

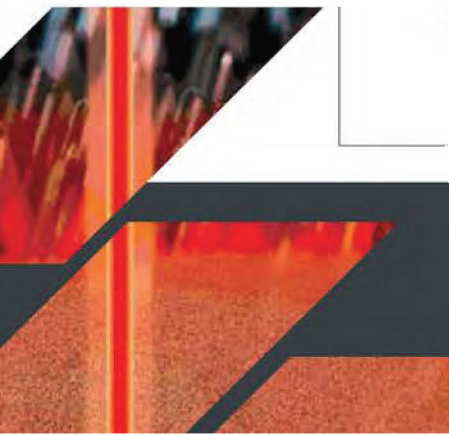
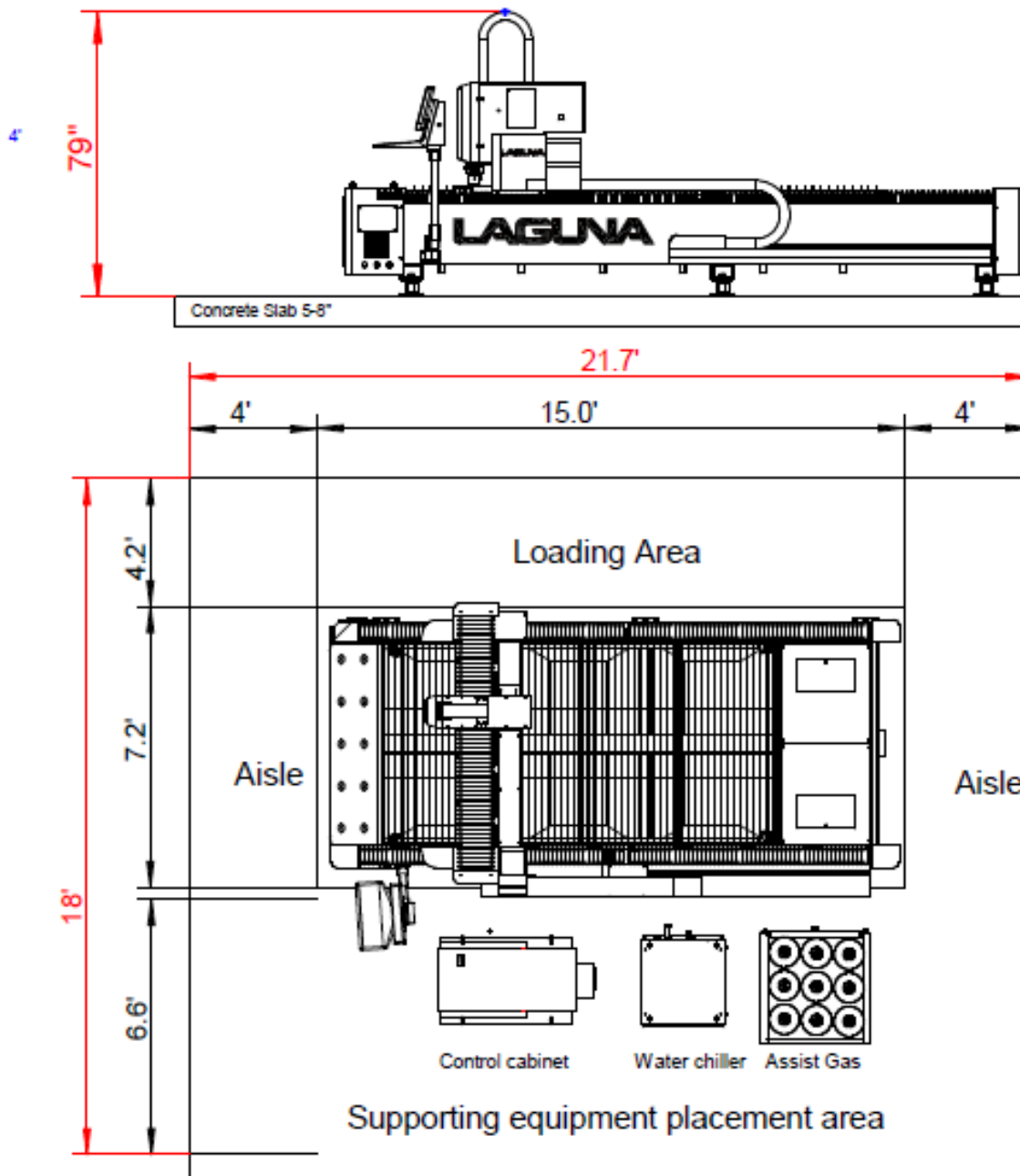

LAGUNA LASER

LAGUNATOOLS.COM

800.234.1976

THE LAGUNA SMARTSHOP[®] LASER | FC

6'x13' FC Footprint

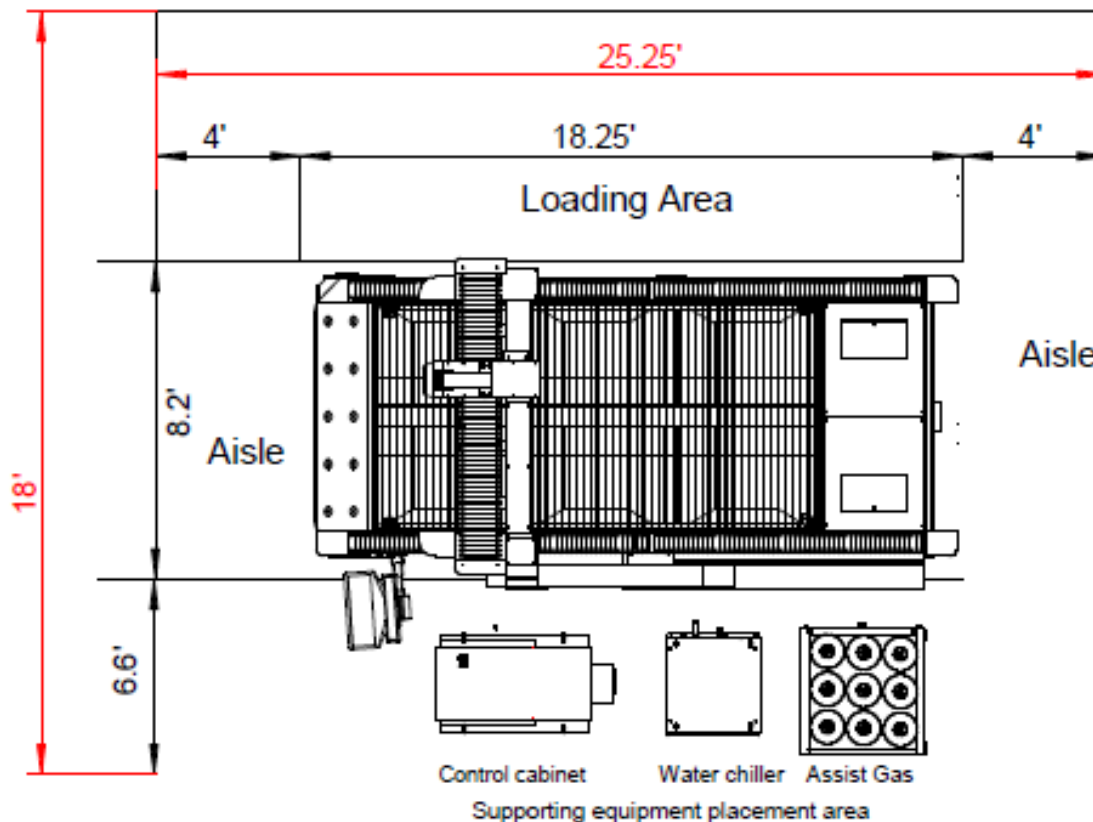
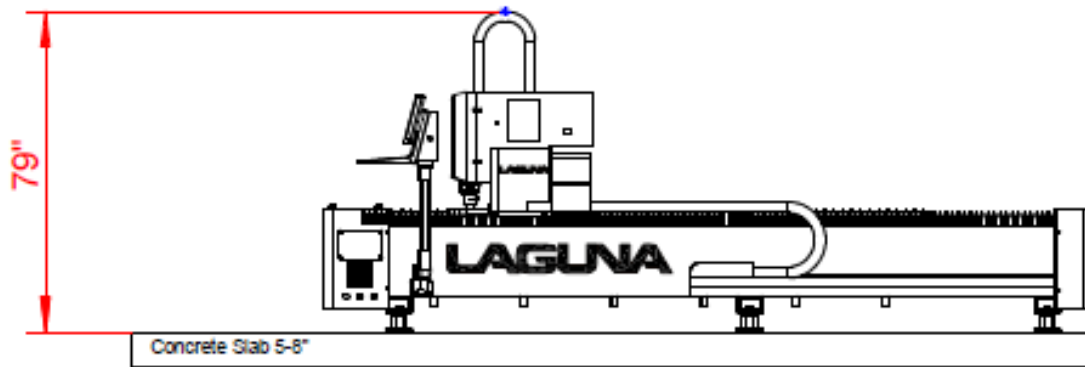

LAGUNA LASER

LAGUNATOOLS.COM

800.234.1976