

# LAGUNA

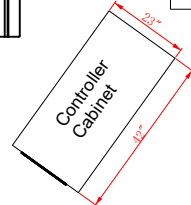

5'x10' \_ 24"

## SMARTSHOP|5 axis

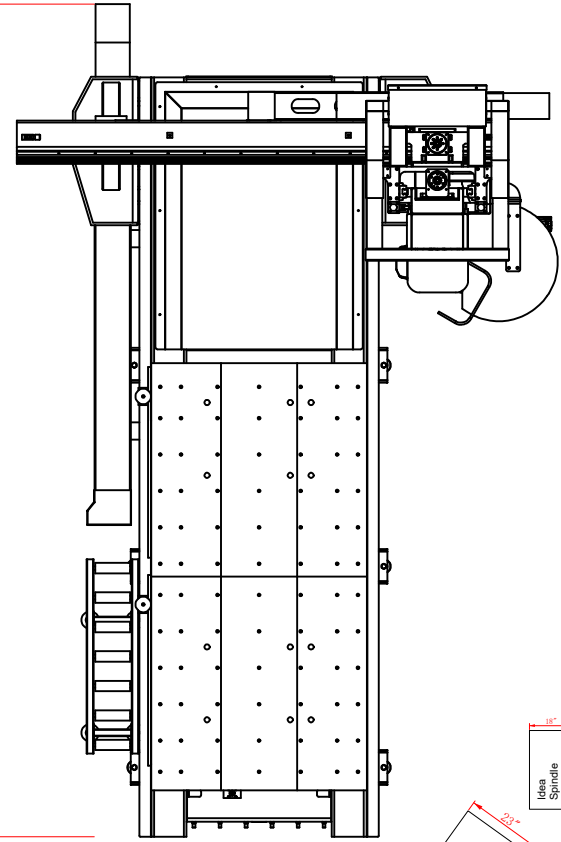
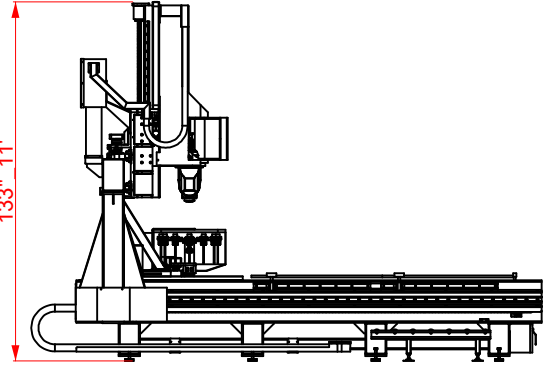

SPECIFICATION:		DRAWN,S.B. 8/26/2025_REV,1	
POWER REQUIREMENTS.	See Below,varies on vacuum choice.		
FOOTPRINT.	143" W X 214" L		
WORKING AREA.	61" x 121"		
GANTRY CLEARANCE.	36"		
ARTICULATING SPINDLE HEAD.	12HP HSD HS300 2 Axis, 9 HP		
SPINDLE RPM.	5,000-18,000 RPM		
RAPID TRAVEL.	Up to 3000 IPM		
MAXIMUM CUTTING SPEED.	1200 IPM		
DUST PORT DIAMETER.	N/A		
PRECISION HELICAL RACK & PINION DRIVE SYSTEM FOR X AND Y AXES	30MM HEAVY DUTY LINEAR BEARING ALL AXES		
CONTROLLER.	Fanuc 311-B5 with Data Server		
SERVO MOTORS	FANUC, 1500W SERVO SYSTEM		
SOLID STATE HOME SWITCH'S.	YES		
HEAVY DUTY WELDMENT TUBULAR STEEL FRAME.	8600 POUNDS		
CENTRALIZED LUBRICATION SYSTEM FOR ALL AXES.	YES		
VACUUM TABLE	6 ZONES , POD ready NEMI standard		
TOOL CONE STYLE	HSK63F		
TOOL CAPACITY	12 Position Rotary Tool Changer		
BORING BLOCK CAPABLE	YES, 5X5 HSD Boring Block(Optional)		
VACUUM OPTIONS:	MACHINE POWER BASED ON VACUUM CHOICE		
2 pcs,10hp stock regen vacuum_3 phase	220v,3 Phase,70 amps		
2 pcs,10hp Becker SV400 vacuum_3 phase	220v,3 Phase,80 amps		
2 pcs,8.6hp Becker Vane vacuum_3 Phase	220v,3 Phase,90 amps		
2 pcs,12hp Becker Vane vacuum_3 Phase	2pcs,Remote starters, 220v,3ph,90 amps. Optional, 480v,3ph,60 amps. CNC Motion 220v,3 phase,30 amps		

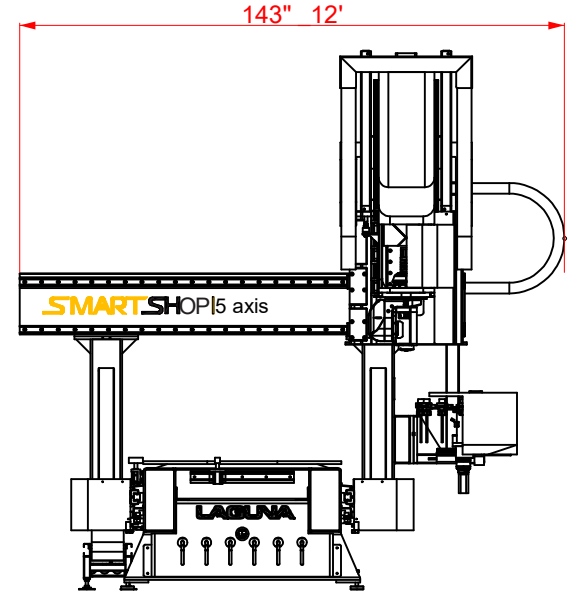

5-AXIS, 5'x10', 24" GANTRY  
 LAGUNATOOLS, GRAND PRAIRIE, TEXAS  
 8/26/2025, S.B., REV,1